



MNOSHA Instruction **STD 1-11.9**

January 31, 2011

Updated to Accessible format July 25, 2024

SUBJECT: Enforcement of the General Industry Crane Standards

Purpose:

To provide guidelines for citing hazards on overhead and gantry cranes covered by 1910.179; and monorail systems, underhung cranes and other hoisting equipment covered by Minnesota Rules 5205.1200-1220.

Scope:

This instruction applies MNOSHA-wide.

Cancellation:

This instruction supersedes MNOSHA Instruction STD 1-11.9, Enforcement of the General Industry Crane Standards, dated July 19, 2005.

Background:

- A. 1910.179 applies to overhead and gantry cranes having a top-running bridge with multiple girders. The cranes covered have the end-truck wheels and trolley wheels running on top of a track. Included are: semi-gantry; cantilever gantry; wall cranes; storage bridge cranes; and other types of cranes having the same fundamental characteristics.
- B. 1910.179 does not apply to any crane, derrick, or hoist having a maximum rated capacity of one ton or less. Also excluded from this standard are monorails; monorail or underhung cranes; top-running single-girder (underhung hoist) cranes; railway or automobile wrecking cranes; skip hoists; hoist-like units used for horizontal pulling only; mine hoists; conveyors; shovels; drag line excavators or backhoes; or any equipment within the scope of mobile scaffolds, towers and platforms.

- C. Minnesota Rules 5205.1200 through 5205.1220 apply to all cranes listed in B. above, which are excluded by 1910.179.
- D. 1910.179(b)(2) requires all new overhead and gantry cranes that were constructed and installed on or after August 31, 1971 to meet the design (construction and installation) requirements of ANSI B30.2.0-1967.

The following sections of 1910.179 are taken from the "Construction and Installation" requirements section of the source document, ANSI B30.2.0-1967:

(b)(3) Modification	(f)(2) Holding brakes
(b)(4) Wind indicators and rail clamps	(f)(3) Control braking means
(b)(5) Rated load markings	(f)(4) Brakes for trolley and bridges
(b)(6) Clearance from obstruction	(f)(5) Application of trolley brakes
(b)(7) Clearance between parallel Cranes	(f)(6) Application of bridge brakes
(c)(1) Cab locations	(g)(1) General - electric equipment
(c)(2) Access to crane	(g)(2) Equipment
(d)(1) Location of footwalks	(g)(3) Controllers
(d)(2) Construction of footwalks	(g)(4) Resistors
(d)(3) Toeboards and handrails for footwalks	(g)(5) Switches
(d)(4) Ladders and stairways	(g)(6) Runway conductors
(e)(1) Trolley stops	(g)(7) Extension lamps
(e)(2) Bridge bumpers	(h) Hoisting equipment
(e)(3) Trolley bumpers	(h)(1) Sheaves
(e)(4) Rail sweeps	(h)(2) Ropes
(e)(5) Guards for hoisting ropes	(h)(3) Equalizers
(e)(6) Guards for moving parts	(h)(4) Hooks
(f)(1) Brakes for hoists	(i) Warning devices

- E. Court rulings have put the burden of proof on the employer to show that existing cranes were installed before August 31, 1971, and are, therefore, exempt from the construction and installation requirements of 1910.179. If the employer is unable to provide that proof, the cranes must conform to all requirements of 1910.179.

References:

- A. **ANSI B30.2.0-1967** is the source document for the 1910.179 standard and contains further definitions and diagrams that correspond with the standard. ANSI B30.2.0-2005 is the most current edition.

- B. **ANSI/ASME B30.17-2006**, "Overhead and Gantry Cranes" is the most current ANSI standard relating to the requirements of 1910.179.
- C. **ANSI/ASME B30.11-2010**, "Monorails and Underhung Cranes" is the most current ANSI standard relating to this type of equipment covered by Minnesota Rules.
- D. **ANSI/ASME B30.16-2007**, "Overhead Hoists (Underhung)" is the most current ANSI standard relating to hoists covered by Minnesota Rules.
- E. **DOE-STD-1090-2007**, "Guidelines for Hoisting and Rigging Activity" Chapter 7 – contains diagrams that correspond with the standard.

ACTION:

- A. When apparent violations or hazards are observed on a crane during an inspection, there are some basic questions that need to be answered by the OSHI to determine the appropriate action to be taken. Before citing any crane under 1910.179, the following questions must be addressed, with the appropriate information included in the Instance Description on the violation worksheet (MNOSHD-1B).
 - 1. Is the crane capacity 2,001 pounds or greater?
 - 2. Does the crane have a top-running bridge?
 - 3. Does the crane have a top-running hoist trolley?
 - 4. Is the crane a type of overhead or gantry crane otherwise covered under 1910.179?
- B. If the answer to **any** of the above four questions is "NO", the 1910.179 standards **do not apply** and the OSHI should cite the appropriate section of Minnesota Rules.
- C. If the answers to **all** four questions are "YES", then the OSHI should use the following to determine whether to cite the hazard under 1910.179 or MN Stat. 182.653 subd.2 (General Duty Clause).
 - 1. If the crane was installed on or after August 31, 1971, then it must meet all the requirements of 1910.179. The date of installation is to be included with the MNOSHD-1B worksheet documentation, or an explanation of the employer's failure to provide this information is to be documented. The OSHI should make a reasonable effort to determine the date of manufacture to avoid an improper citation.
 - 2. If the crane was installed before August 31, 1971, and the employer has provided sufficient proof to that effect, only the inspection, testing, maintenance, and operation requirements of 1910.179 can be cited. The standards dealing with construction and installation are not enforceable and are not to be cited.

3. If a crane was installed before August 31, 1971, **and** originally met the construction and installation requirements, it can be cited for lack of proper inspection, testing, or maintenance if a hazard exists. If the manufacturer originally recognized the need for, and safety provided by, construction and installation features provided in the design requirements, these must be maintained, even if installed before August 31, 1971.
 4. Regardless of when it was installed, if the crane has defects or hazards of a serious nature that are not specifically covered or excluded by the 1910.179 standard, the OSHI should cite MN Stat. 182.653 subd.2 if elements exist for a General Duty citation, as outlined in the FCM.
- D. Cranes that have defects or hazards that do not fall under 1910.179 or the Minnesota Rules, or are not serious enough to be cited by General Duty, should be discussed with the employer with the recommendation that the hazard be voluntarily corrected to avoid an accident.

James Krueger, Director MNOSHA Compliance

Distribution: OSHA Compliance and Workplace Safety Consultation Director

NOTICE: Minnesota OSHA Directives are used exclusively by MNOSHA personnel to assist in the administration of the OSHA program and in the proper interpretation and application of the occupational safety and health statutes, regulations, and standards. They are not legally binding declarations, and they are subject to revision or deletion at any time without notice.

CRANE EXAMPLES

* Top-running single- or multiple-girder bridge with top-running trolley hoist.

*These types of cranes are enforced under the 1910 Standards

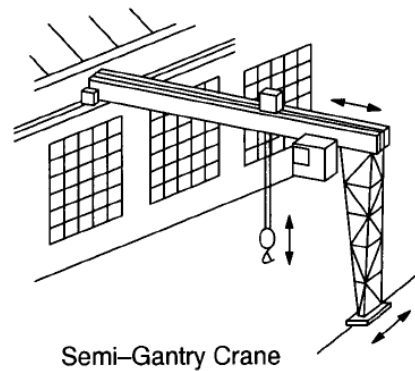
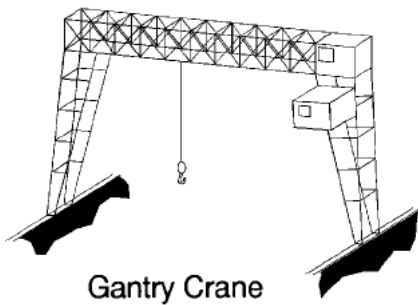
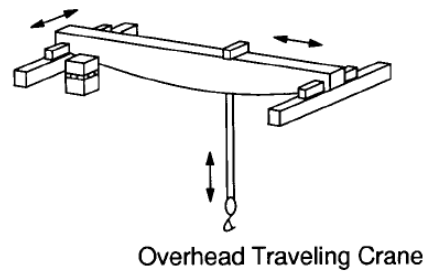
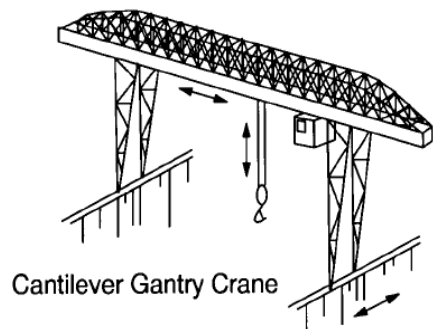

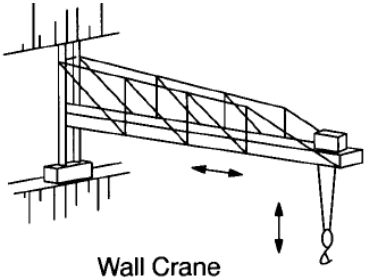

Wall Crane

All photos from DOE-STD-1090-2001
Chapter 7 – Overhead and Gantry Cranes

* Top-running single-girder bridge with underhung trolley hoist.

*These cranes are enforced under the Minnesota Rules

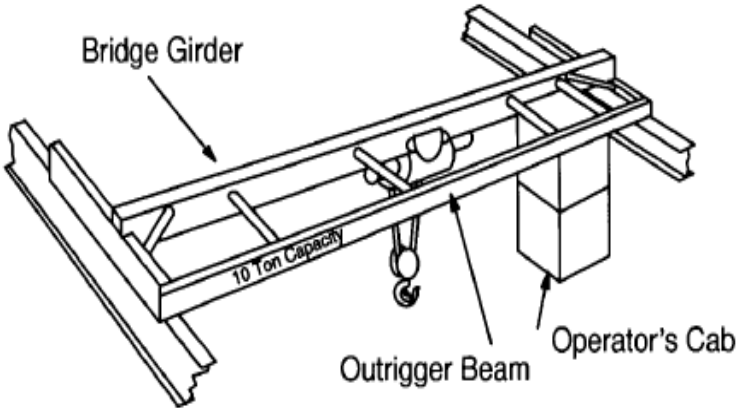

Overhead Cab-Operated Crane

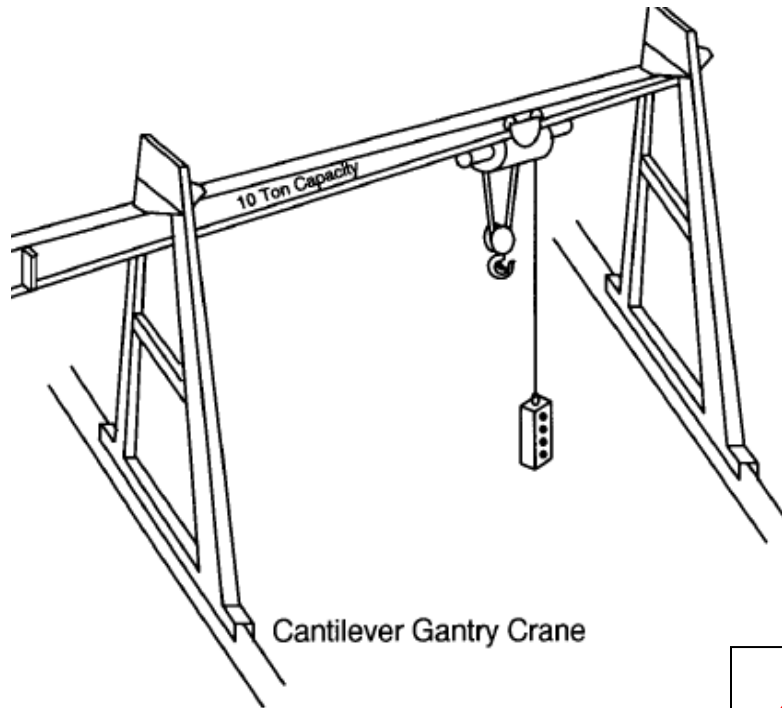

All photos from DOE-STD-1090-2001
Chapter 7 – Overhead and Gantry Cranes

* Monorails and underhung cranes.

*These cranes are enforced under the
Minnesota Rules

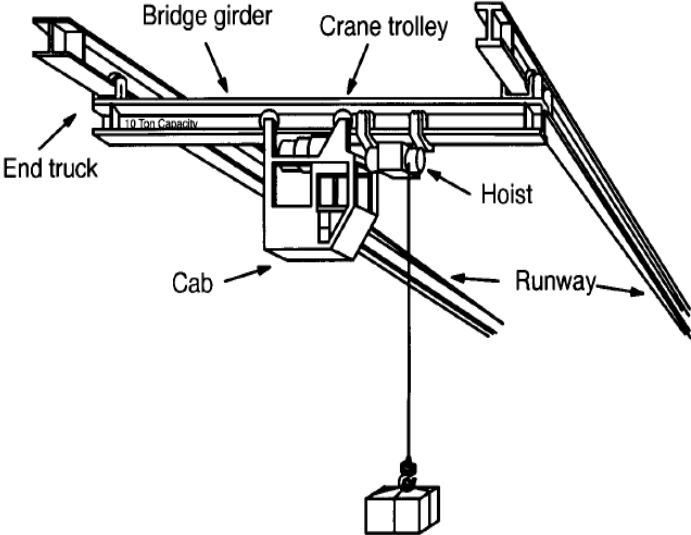

Cab-operated crane

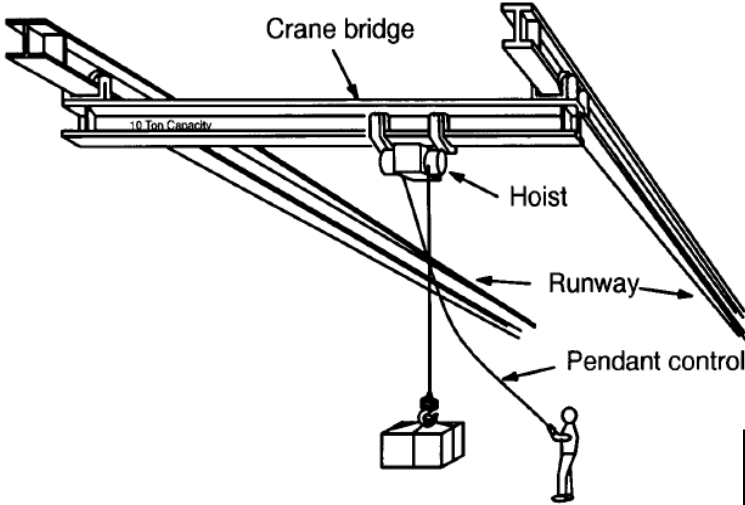

Floor-operated crane

All photos from DOE-STD-1090-2001
Chapter 7 – Overhead and Gantry Cranes