

**2012 MN ENERGY CODE: DUE DILIGENCE REVIEW OF PERFORMANCE
AND PRESCRIPTIVE FOUNDATION SYSTEM MOISTURE DURABILITY RULES WITH
R-15/R-19 WALL THERMAL INSULATION**

Principal Investigator: Louise F. Goldberg Ph.D (Eng)
Energy Systems Design Program
Dept. of Bioproducts and Biosystems Engineering
University of Minnesota

Program Manager: Stephen Hernick
Assistant Director/ State Building Official
Construction Codes and Licensing Division
MN Dept of Labor and Industry

A. INTRODUCTION

The model energy code promulgated by the International Code Council, as referenced in the American Recovery and Investment Act (ARRA) by the Federal Government is the 2009 International Energy Conservation Code. The ARRA requires that the minimum level of thermal insulation on foundation walls be increased over Minnesota's Current Energy code to R_{US} -19 for cavity insulation and R_{US} -15 for continuous insulation (typically rigid or semi-rigid board insulation). The Division is considering carrying forward the prescriptive and performance foundation durability rules developed for and included in the current MN Energy Code into the 2012 Code for foundation insulation systems. (Note: the requirements in the 2012 International Energy Conservation Code for foundation insulation are identical to the 2009 International Energy Conservations Code (IECC)). MN Statute 326B.118 requires the Department of Labor and Industry to perform the necessary building science due diligence to ensure that adoption of the R-19/R-15 foundation wall insulation requirement will not compromise the building durability and moisture performance of the carried-forward rules that were based on a foundation wall thermal resistance of R-13/R-10.

This report embodies the required building science due diligence review and focusses on the following topics:

1. Review of the performance criteria (MN Statutes, 1322, N1102.2.6.12) with regard to omissions, clarity of language as well as research results and data that have materialized since the previous due diligence study was published in 2005 (Goldberg and Huelman, 2005). These criteria also have been published in the peer-reviewed technical literature (Goldberg, Huelman and Gatland, 2010).
2. Review of the existing rules that cover interior and exterior insulation placements with a focus on the changes necessary to implement the R-19/R-15 requirement and to bring those rules into compliance with the performance criteria. Very careful consideration is given to the prescriptive requirements for interior R-19 cavity insulation in the light of experimental data that demonstrates the occurrence of significant condensation on the interior surface of any interior condensation plane.

3. Development of new prescriptive rules for split rigid/semi-rigid board insulation systems with R-10 on the interior and R-5 on the exterior and vice versa. These rules will be in compliance with the performance criteria.

The Division has indicated that the integral foundation system (2012/R402.1.1.1) does not require additional review.

B. BUILDING SCIENCE REVIEW

The review was undertaken as a combination of hygrothermal simulation together with the relevant available experimental results. The simulations were restricted to hollow core cement masonry unit (CMU) walls only as these are the worst case. Hygrothermally, poured concrete walls are more durable than CMU walls owing to the absence of vapor filled cores and thus were excluded as a means of executing the review within the imposed budgetary constraints. Thus the rule recommendations for CMU walls also apply to poured concrete walls. Wood foundation walls were excluded from the review and the hygrothermal data presented in this report do not apply to these walls.

B.1 Simulation Methodology

The simulations have been performed using the WUFI-2D version 3.3 simulation program developed by the IBP, Fraunhofer Institute, Germany. A technique for applying the program to below-grade hygrothermal transport known as the Equivalent Soil Layer (ESL) methodology (being developed in collaboration with the DOE Oak Ridge National Laboratory) was invoked in order to apply the program in the below-grade context. As this technique has not yet been validated against experimental data¹, it has been deployed here in a very structured manner so as to yield physically meaningful comparative or relative results. Notwithstanding its limitations, currently, the WUFI-2D/ESL is the only computationally tractable methodology available for performing the required quantitative review.

Thus the simulation strategy was based on an accretive sequence of changes to a baseline wall system so that the effect of each change can be seen relative to the previous stage. Thus the simulation sequence was:

- bare wall (no insulation, WSP's, vapor retarders, etc)
- bare wall with wall interior WSP
- bare wall with wall interior WSP and interior cavity insulation system
- bare wall with wall exterior WSP and interior cavity insulation system
- bare wall with wall exterior and footing top WSP and interior cavity insulation system
- bare wall with a full wall interior WSP, wall exterior WSP to grade and interior cavity insulation system
- bare wall with full wall interior and exterior WSP's and an interior cavity insulation system
- bare wall with full wall exterior WSP, exterior R-10 and interior R-5 rigid insulation
- bare wall with full wall exterior WSP, exterior R-5 and interior R-10 rigid insulation

¹ A project funded by DOE/ORNL to collect the necessary experimental data and collaborate on validating the ESL has been initiated at the ESDP, Univ. of Minnesota. Results of the project are expected to be published in the winter of 2013/14.

WUFI-2D is based on a two-transport property model with temperature and relative humidity (RH) as the transport properties (equations 48 and 49 in Kunzel, 1995). The temperature transport property is expressed in an energy balance equation while the RH is included in a composite mass balance equation. The material moisture content is related to the RH via a sorption isotherm and the liquid transport (diffusion only) is related to the RH via an empirically determined liquid conduction coefficient for the materials under consideration (equation 23 in Kunzel, 1995). This lumped parameter approach to combined vapor and liquid transport is in the same class as the perhaps more rigorous Multiphase Flow Model (Richards equation) and Multiphase Mixture Model (Wang and Chen, 1997). Lumped parameter models are attractive in this context because they are computationally tractable for building simulations that generally require at least 17520 hours and order 10^4 nodes (for a two-dimensional model) for a physically reasonable result². However, the absence of a discrete liquid (or bulk water) transport equation is a significant limitation because it militates against important phenomena such as condensate rundown and exterior bulk water leakage being modeled accurately.

Thus as these bulk water effects are not explicitly included in WUFI-2D, the results are inherently limited to those produced by water vapor transport and the associated liquid diffusion derived from the vapor transport using empirical correlations. Thus independent bulk water phenomena, that is, phenomena unrelated to vapor transport (such hydrostatic pressure induced leakage), are not included in the simulation. In other words, when present, actual bulk water phenomenology has a larger impact on the durability assessment than the vapor transport impacts simulated. More simplistically, a vapor transport sourced durability failure indicated by WUFI-2D is almost certainly more dire in reality in a below grade context. With this understanding of the limitations of the WUFI-2D results in a below-grade environment, the vapor transport sourced results produced are physically meaningful qualitatively and provide sufficient insight for conducting the review with the understanding that durable foundation envelope systems require the elimination of bulk water intrusion to the greatest extent possible. However, the results presented are compared with experimental data when available so that the deficiencies of WUFI-2D are made manifest and, in the presence of non-congruency between the experimental and simulation data, preference can be given to the experimental data.

The basic simulation domain is shown in Figure B.1. The same wall geometry deployed at the FTF (that provided the experimental basis for the previous 2005 review) was used here as well for consistency. Thus the geometry represents a cross section through the core of a standard 12 in. wide CMU wall built on a standard poured concrete spread footing. The above-grade wall height was set at 18 in. (the same as the FTF basement test modules) and the equivalent soil layer (ESL) was based on a Lowell sand, similar to the engineered soil around the FTF test modules. The vertical soil boundaries were taken to be adiabatic with zero mass flux, while the horizontal deep ground boundary was at the well water temperature for Minneapolis with the soil being saturated. The ambient weather conditions were those of the Typical Meteorological Year Series 3 for Minneapolis. The transient basement interior temperature and RH boundary conditions were calculated from the ambient weather data according to ASHRAE Standard 160 with the RH being calculated using the intermediate method (flowchart 3). The soil initial condition was established as being vapor-saturated as is typical for Minnesota soils.

Each simulation was run for two calendar years with the first year being used to establish the soil boundary conditions for the second year. Two years of simulation was insufficient to establish hygrothermal equilibrium that generally requires 5 to 10 years. However, time and

² Tractable in this case is relative. Typically, each WUFI-2D simulation included in this report required 20 hours of computation.

budgetary constraints precluded such long computations (100-200 hours), hence the results necessarily represent a transient, pre-equilibrium assessment of the hygrothermal performance.

Some effort was expended in attempting to model bulk water leakage into the structural wall system. However, this effort did not yield any results as the program failed to complete an annual simulation owing to the occurrence of a consistent convergence error. Clearly this defect will have to be addressed in future research.

The results of the simulations and associated experimental data are presented in Sections B.2 through B.10. In each section, the discussion is presented first followed by the pertinent figures.

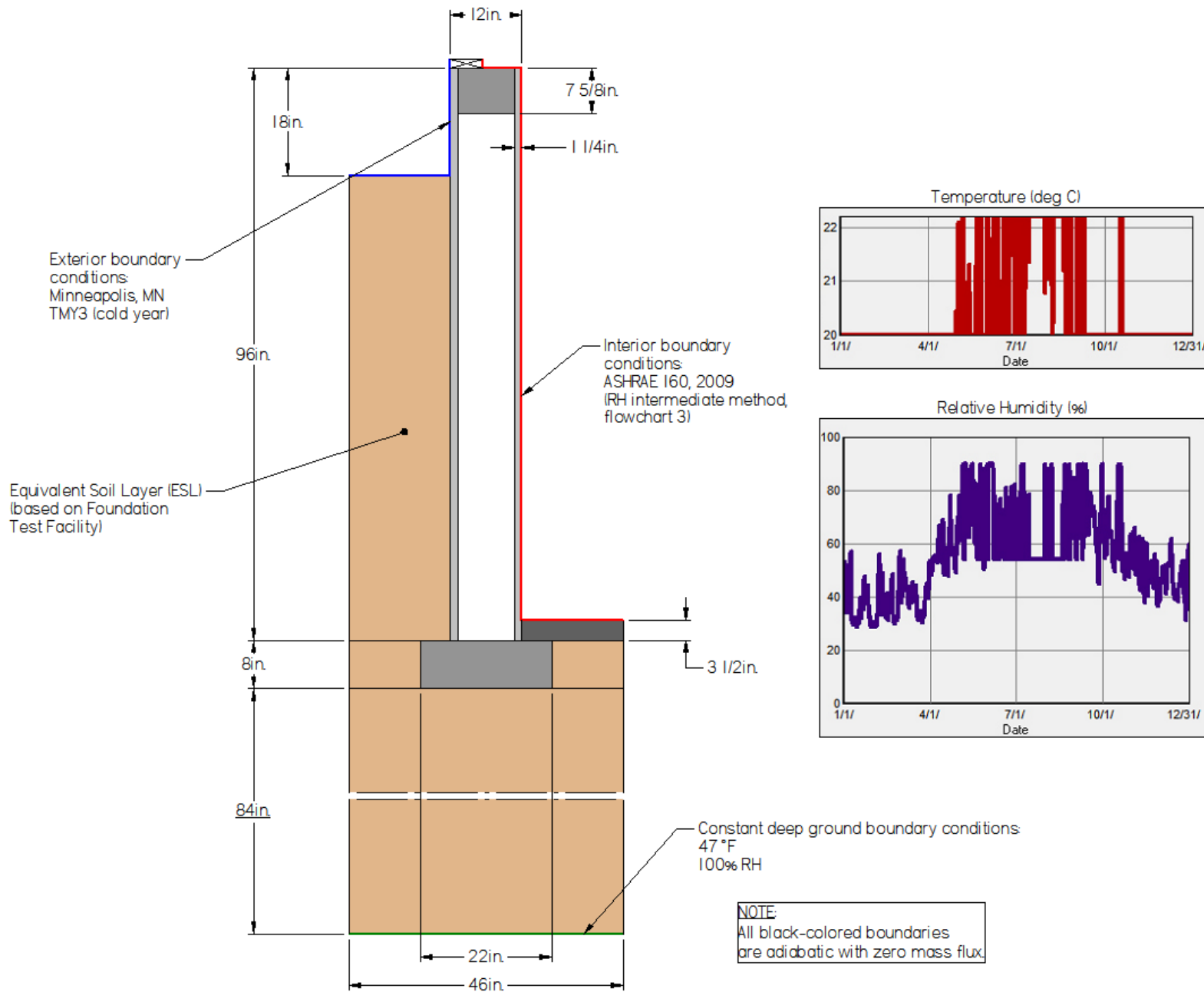

Figure B.1 Wall system hydrothermal calculation domain

B.2 Base Masonry Block Wall without Insulation or a WSP

The configuration of the base case is shown in Figure B.2. The top course of the wall was assumed to be solid with no steel reinforcement, although the mechanism by which the solidity was achieved (filled cores, bond beam, etc) was not specified.

The results are given in Figure B.3 which depicts a horizontal traverse of RH on the condensation planes at three wall heights, namely, at the center of the above-grade wall, 12 in. below grade and mid-height on the below-grade wall. This methodology is repeated for all the simulation results.

Figure B.3 reveals that on all the condensation planes at all vertical locations, no condensation occurred (RH = 100%) throughout the simulation period. However, the below-grade wall exterior surfaces operated at RH's in excess of 96% in transient equilibrium with the vapor-saturated soils. It is very important to understand, that in the context of CMU's for the particular concrete mix chosen, vapor saturation (RH = 100 %) does not correspond to liquid saturation. Thus at 100% RH, the liquid saturation ratio (pore liquid volume / pore total volume) is 81.6 %. Structural impacts produced by freeze/thaw cycling only occur after the saturation ratio reaches a critical value of 91.68% (at atmospheric pressure), hence saturated RH's are not necessarily indicative of a structural failure condition.

Thus these data show that the base CMU foundation walls without any WSP's did not result in any moisture accumulation on the condensing surfaces, in agreement with observation.

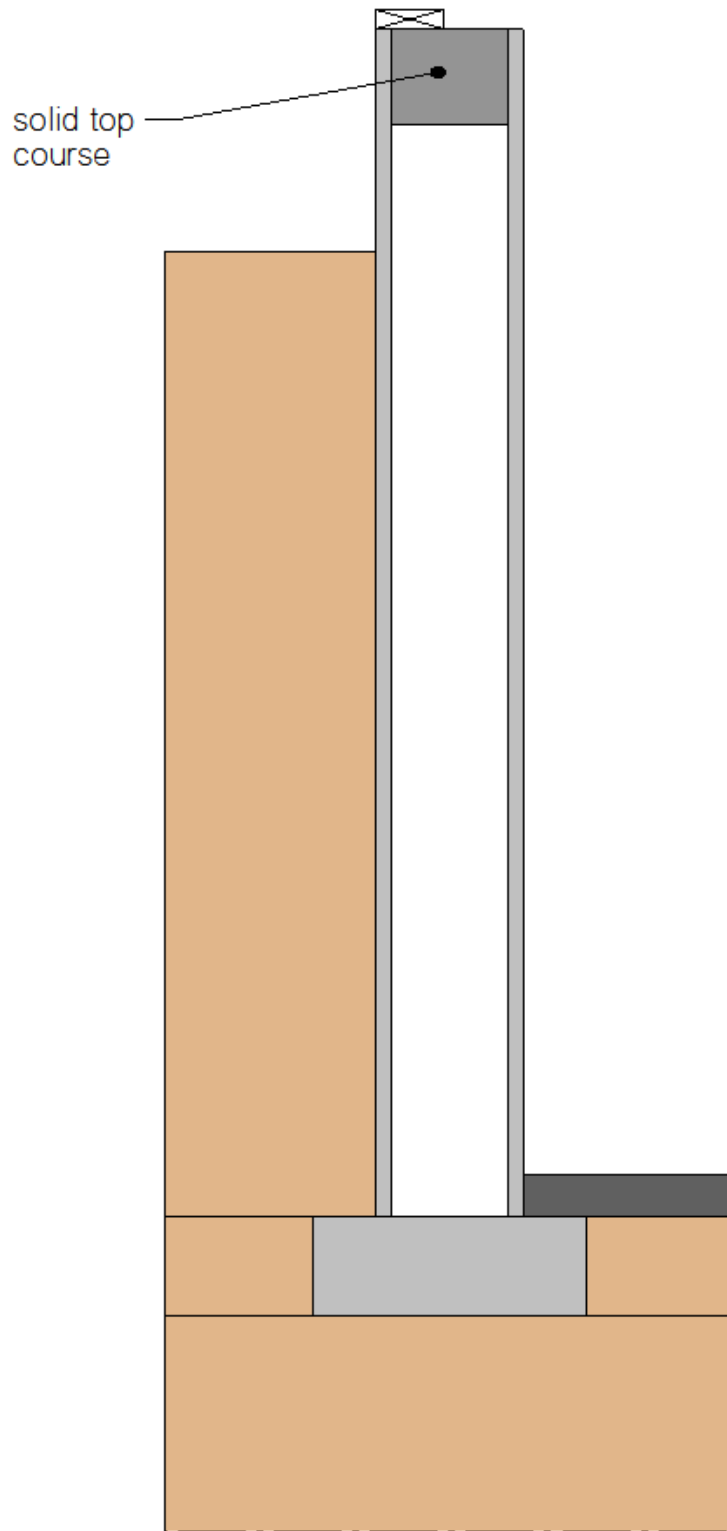

Figure B.2 Base masonry block wall simulation configuration (“Base”)

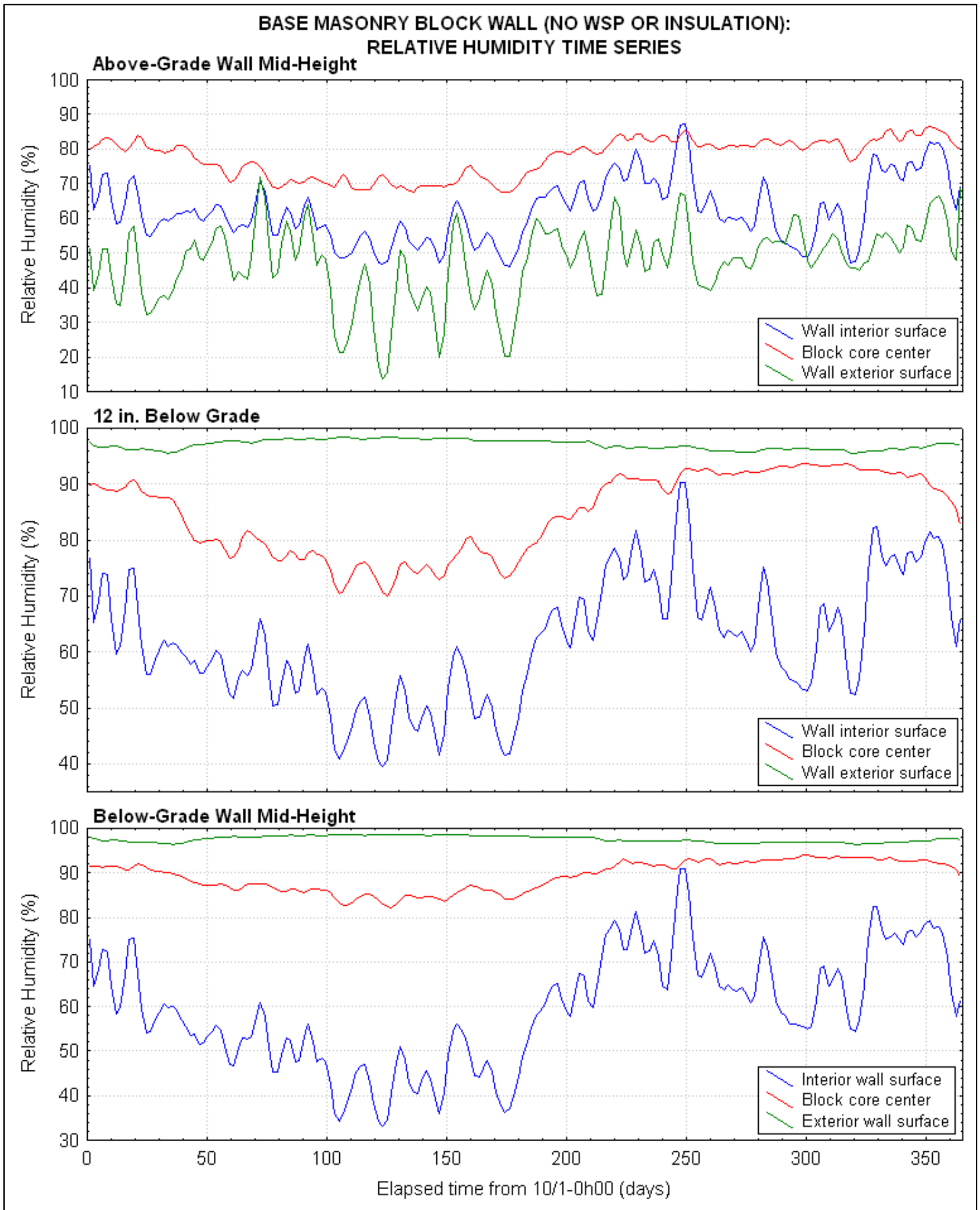

Figure B.3

B.3 Masonry Block Wall with an Interior Non-Adhered WSP and without Insulation

An interior WSP was added to the base wall in Figure B.4. In keeping with the performance criteria (and the previous review, Goldberg and Huelman, 2005), the WSP was extended over the top surface of the wall as well. Generally, there are two approaches to installing WSP's, adhered or non-adhered. As a non-adhered WSP introduces a drainage gap between the wall and the WSP, it creates the possibility for mold to develop on the bounding surfaces if any nutrients are present (this was observed in practice at the Foundation Test Facility). Thus in this sense, a non-adhered WSP is a worse case than an adhered WSP and thus was adopted for this review.

However, it should not be inferred that an adhered WSP (spray applied, or adhesively attached) is necessarily better. Certainly the air gap and associated potential for mold growth are removed, but the potential for delamination on a liquid saturated wall is created for an adhesively attached WSP and the potential for higher liquid saturation ratios in the interior CMU shell is created in both cases. These higher saturation ratios may increase the risk for freeze/thaw cycle structural damage.

The results of the simulation are shown in Figure B.5. Once again the wall exterior surface RH operated above 96% RH, in transient vapor equilibrium with the soil, as in the base case. The critical metric however is the RH on the exterior (wall side) surface of the WSP. At all vertical locations, the RH did not exceed about 85% with the highest values occurring from 12 in. below grade upwards. Also of note is that all the RH profiles were in approximate cyclic equilibrium after 2 years of simulation with the initial and final RH's being within 2% of each other.

Thus adding an interior WSP without any interior insulation also did not produce condensation on any of the wall surfaces.

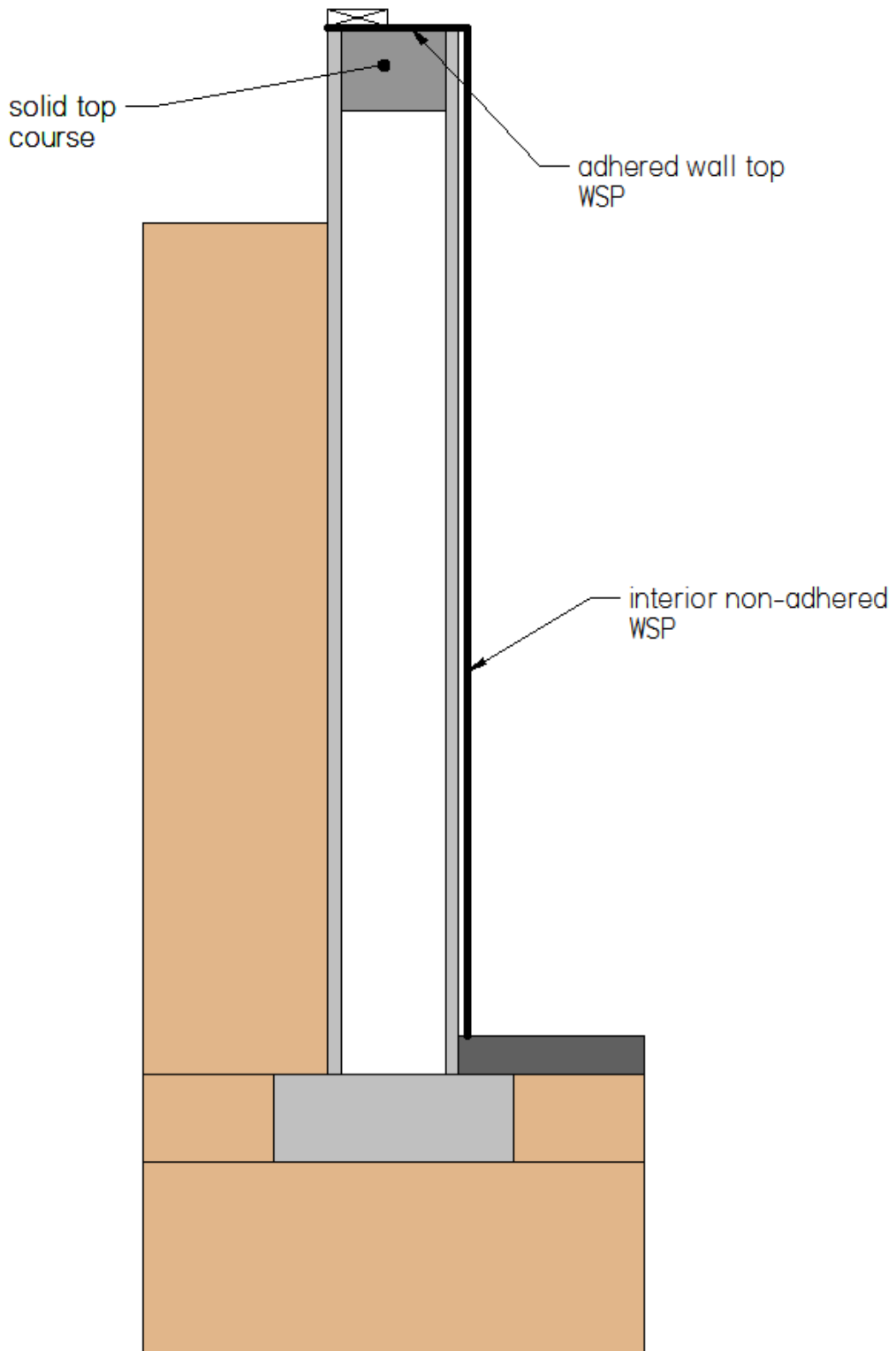

Figure B.4 Base + non-adhered interior and adhered wall top WSP ("Base-IWSP")

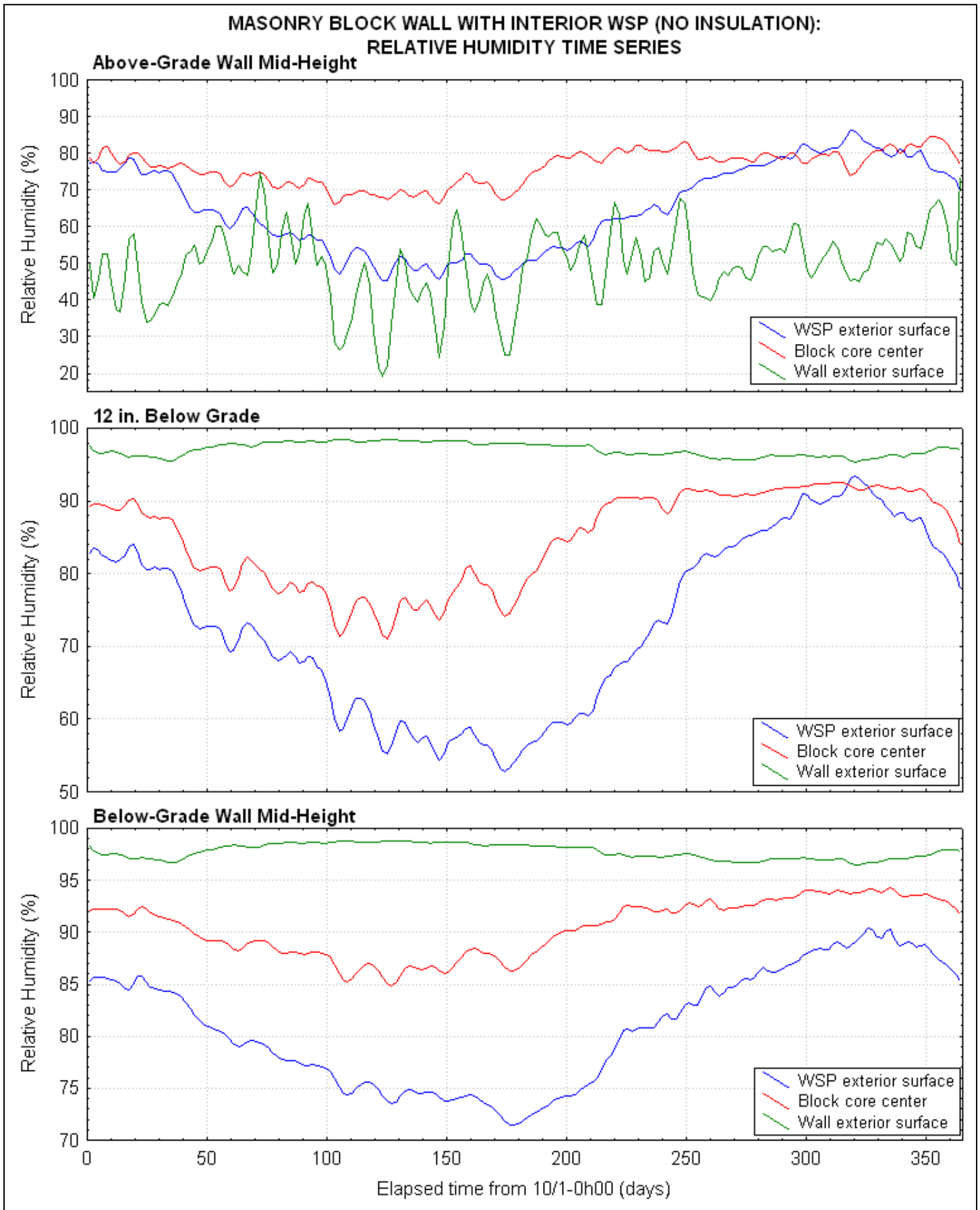

Figure B.5

B.4 Masonry Block Wall with an Interior Non-Adhered WSP, R-19 Cavity Insulation and a 2-mil. PA-6 Warm Side Vapor Retarder

The addition of interior insulation to the previous interior WSP system is shown in Figure B.6. This configuration begins to address one of the core tasks of assessing the durability of R-19 fiberglass batt cavity insulation systems. In the previous review (Goldberg and Huelman, 2005), interior fiberglass batt cavity insulation was excluded from the prescriptive recommendations for interior insulation systems on the grounds of the poor hygrothermal durability of all vapor permeable (class III) insulations when installed with a warm-side polyethylene vapor retarder (Goldberg and Aloj, 2001, Goldberg, 2002).

In a subsequent experiment conducted at the Foundation Test Facility (FTF), the moisture durability of fiberglass batt cavity insulation with a 2-mil. PA-6 (polyamide-6) warm side vapor retarder was assessed (Goldberg, 2006, published after the 2005 review). PA-6 has a RH dependent vapor permeance that is in class II (0.1 to 1 perm) under ASTM E96A (dry cup) test conditions and in class III (> 1 perm) under ASTM E96B (wet cup) test conditions. The results of the experiment yielded the conclusion that “Full-height, bare masonry block walls with no more than 18” of the wall above grade that are insulated with unfaced fiberglass batts and covered with an interior, air-sealed PA-6 vapor retarder meet the performance requirements of the MN Energy Code Building Foundation Rule Proposal Final Report³”. Thus this was the basis for evaluating the performance of the fiberglass batt cavity insulation system in this review.

Thus the insulation system simulated is shown in Figure B.6 and includes an interior WSP, a 2 x 6 stud frame cavity with unfaced R-19 fiberglass batt cavity insulation, a warm side 2-mil. PA-6 vapor retarder and 0.5 in. gypsum wall board.

The surface condensation results are shown in the RH profiles of Figure B.7. Immediately noticeable are the long periods of surface condensation on the interior surface of the WSP from 12 in. below grade upwards. At the below-grade mid-height location, no WSP interior surface condensation occurred. 12 in. below grade, the condensation occurred from 11/30 through 5/4 (5 months), while above grade it occurred from 1/10 through 3/1 (~2.5 months). Noting that WUFI-2D does not model bulk water flows, all of this condensate would run down the interior surface of the WSP and pool on the floor (shown experimentally below). Thus this configuration did not meet the following performance criterion:

- N1102.2.6.12.1 -3: liquid water would reach the foundation floor system.

The balance of wall system exterior to the WSP did not show any evidence of surface condensation as expected from the results of the previous section (that is, the WSP indeed hygrothermally separates the interior and exterior environments). However, the exterior WSP RH (in hygric equilibrium with the wall interior surface and drainage gap) experienced RH's in excess of 90% for the entire year that leads to the often asked question as to whether there is a severe mold problem in the drainage gap.

This question was addressed in Figure B.8 that depicts the RH/temperature point distribution in the drainage gap at the three vertical evaluation locations (note that the values plotted are the averages across the air discrete volumes in the drainage gap – this is slightly more conservative than using the values in the air just adjacent to the surfaces). Also shown are mold isopleths for two classes of nutrient base (Sedlbauer, 2001, Selbauer, Krus and Breuer, 2003). Substrate

³ Goldberg and Huelman, 2005, chapter 7 that formed the basis of the performance criteria in the 2009 MN foundation rules.

class 1 is classified as being bio-utilizable, that is, it provides sufficient nutrients for molds to grow, while substrate class 2 has poor nutrient availability. Thus an annual temperature/RH distribution to the right of a substrate mold isopleth indicates that the temperature/RH conditions experienced have the potential for growing mold on that substrate. Thus Figure B.8 shows that the potential for mold growth on a class 2 substrate existed at the below-grade wall mid-height location for the entire year and at 12 in. below grade for most of the year. Above-grade, mold growth on a class 1 substrate was possible for about less than half a year.

However, while these data suggest that mold can occur in the drainage gap, they do not warrant the conclusion that mold will occur on substrates with less nutrients than class 2 such as the WSP (typically plastics or rubber, such as polyethylene and ethylene propylene diene monomer rubber) and CMU concrete surfaces. As shown in Figure B.9, a particular case of a 15-year experiment conducted at the Cloquet Residential Research Facility, mold growth in fact did not occur in the drainage gap owing to the absence of nutrients, even when the drainage gap was wet with visible bulk water. However, the PI has observed isolated small pockets of mold growing in the folds of a polyethylene interior WSP during an experiment at the FTF. Of further interest in Figure B.9 is the extent to which the drainage gap can become very wet and, in this particular case, has been observed to remain wet for prolonged periods.

Generally, mold growth can only grow on non-nutrient surfaces with the introduction of external nutrients (for example, see Hoang et al, 2010). In the case of the drainage cavity, such nutrients can be present as a result of dirty surfaces at the time of installation, air advection (from the interior, exterior or through the soil) as a result of failed air-sealing of the drainage cavity, or cracks in the wall, etc. Thus it seems reasonable to suggest that, in the absence of further experimental evidence, major or exponential mold growth in a well-sealed and initially clean drainage cavity is unlikely over the long term (defined experimentally as up to 15 years at this juncture). However, given the availability of external nutrients, mold growth in the drainage cavity is highly likely.

The ability of the interior shell to dry out was investigated by setting the CMU interior shell to an initial condition of vapor saturation on 7/1. The resulting moisture content profiles for the interior and exterior shells are given in Figure B.10. At all three vertical levels, the interior shell dried out from the vapor saturated condition to an operating equilibrium in 50 days indicating that there is sufficient drying capacity to the exterior in the absence of a wall exterior WSP. Thus without an exterior WSP, in the event that the interior shell becomes wet for whatever reason (for example, an extreme precipitation event, wind-driven rain through cracks, etc) the simulation indicates that there is sufficient drying capacity.

Currently there is no transient quantitative experimental data on the hygrothermal performance of interior WSP's in the University of Minnesota's experimental database. However, such data is available from research performed commercially (that is, external to the University)⁴. This research was conducted by the PI to evaluate the performance of a patented basement interior drainage system (Goldberg and Stender, 2011a and 2011b). The basic experimental configuration is depicted in Figures B.10 and B.13. It is important to note that the experiment was a test of a retrofit application and the focus primarily was to evaluate the drainage functionality and not to evaluate the overall merits of an interior WSP per se. In essence, the interior WSP was placed between the wall and the retrofit insulation system with a drainage gap (non-adhered configuration) on either side. The WSP was configured to drain on both sides to to a channel at its base. Two insulations configurations were tested, a 2 in. semi-rigid fiberglass

⁴ These results are presented by courtesy of Moisture Management, LLC, Chaska, MN. They have been submitted for publication in the Proceedings of the Thermal Performance of the Exterior Envelopes of Whole Buildings XII Conference in 2013 and thus are considered as public domain information.

board with a warm-side 2-mil. PA-6 vapor retarder (Figure B.10) and 2 in. of closed-cell polyurethane foam without a warm side vapor retarder (Figure B.13).

The condensation plane results for the semi-rigid board system are shown in Figures B.12 and B.13 at two vertical locations, one at the above-grade mid-wall height (18 in.) and one at the below-grade mid-wall height. As shown in the bottom panel of Figure B.12, the interior setpoint RH profile was very severe, again for the purpose of testing the drainage performance of the system under extreme conditions. Hence after a period of equilibration through day 36, the interior RH was progressively raised to 72 % at a temperature of 72 °F at day 60. Thereafter the interior RH was lowered in two stages to 46 %. After day 80, humidification ceased allowing the test insulation systems to equilibrate to the interior conditions. At day 98, dehumidification commenced reducing the interior RH to less than 24 %. This severe profile also served to wet the interior CMU shell so that the drainage performance on both sides of the WSP could be evaluated. The mechanism adopted was to leave the laboratory walls bare on both sides of the experimental test panels through day 60 and then cover them with R-10 extruded polystyrene insulation thereafter. Thus prior to day 60, the bare walls absorbed prodigious amounts of vapor that condensed and was transported by diffusion through the interior CMU shell to locations behind the WSP's on the test panels.

The RH results of the experiment for the semi-rigid insulation board are shown in Figure B.12. Condensation persisted on the interior surface of the WSP from day 40 through day 80 above grade and from day 40 through day 108 below grade. However, the exterior face of the WSP reached saturation at about day 88 above grade and day 52 below grade. The wall surface reached vapor saturation at day 60 above-grade and day 50 below grade.

The wetting drying performance of this system is shown in Figure B.13 at the above-grade location and in Figure B.14 at the below grade location. These data show that after the exterior surface of the WSP became wet, it never dried out. The bottom panel of Figure B.13 and B.14 (reproduced on both figures) shows that the drainage channel became wet at day 50 owing to the condensate rundown from both sides of the WSP and remained wet thereafter. The RH in the drainage channel eventually exceeded 95% but never reached vapor saturation.

Replacing the semi-rigid fiberglass insulation with 2 in. of closed cell spray polyurethane (Figure B.15) produced the RH results shown in Figure B.16 with a very similar pattern to that of Figure 12. The salient conclusion here is that 2 in. of closed cell spray polyurethane (ccSPU) offers no better vapor retarding performance than a 2-mil. PA-6 membrane. Hence, in order to achieve the level of vapor retardation achieved by, for example, 2 in. (R-10) of extruded polystyrene insulation, requires a much thicker ccSPU layer (generally in excess of 4 in. for standard residential, non-waterproofing products). Thus the efficacy of using ccSPU in an interior foundation wall application is determined not by its installed R-value, but by its installed permeance. Hence, a hygrothermally effective ccSPU installation would likely have a thermal resistance in excess of R-24.

There are two salient conclusions to be drawn from these interior WSP experimental data making allowances for the big disparity in interior boundary conditions between Figures B.1 and B.12, that is, it is almost impossible to conceive of any residential basement in MN operating at RH levels in excess of 60% during the heating season for any length of time. Firstly, condensation on the interior surface of a WSP at the level shown in Figure B.7 (150 days at 12 in. below-grade, compared with just 68 days mid-wall below-grade in Figure B.12) will drain to the floor and so fail to meet the applicable performance criterion. Secondly, that once the drainage cavity becomes wet, it is likely to stay wet for a protracted period. The extent of this protraction is still unknown.

Closure

The data in this section have demonstrated that, based on the phenomenology on the interior of the WSP alone, an interior WSP cannot be used with vapor permeable insulation systems even with an RH dependent warm-side vapor retarder with hybrid class II / class III permeance characteristics because such systems are not in compliance with the performance criteria.

The data also show that there is a maximum permeance limit that is necessary to prevent condensation on the surface on the exterior side of the insulation (whether moisture absorbent or not) and while clearly in the class II range, this permeance is less than 1. Based on experimental data gathered at the Foundation Test Facility, a permeance about that of 2 in. of Type X extruded polystyrene (ASTM C578), or 0.55 perms was shown to be effective.

Further, the data have shown that while the potential for mold growth in the drainage gap between the interior WSP and the wall exists, in the absence of an external nutrient source, such mold growth is unlikely over a 15 year period. After the drainage cavity between the interior WSP becomes wet, there is evidence to suggest that it can remain wet for prolonged periods. The structural impacts, if any, of such persistent wetness on the interior CMU shell in terms of freeze/thaw cycling have not been determined but it is reasonable to infer that if the wetness persists through the heating season, it is at least prudent to consider that such impacts could manifest themselves.

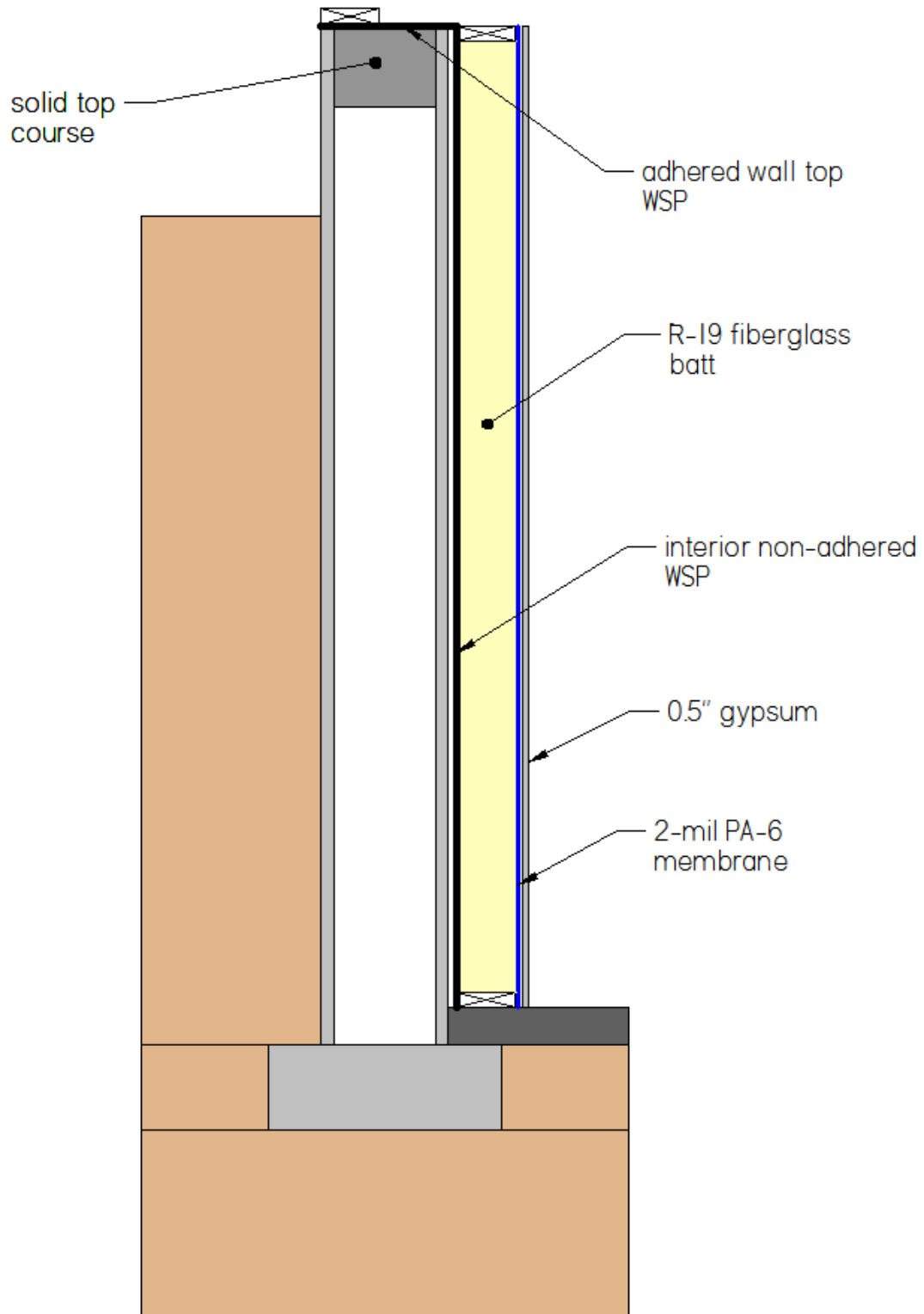

Figure B.6 Base-IWSP + interior R-19 cavity insulation + 2-mil. PA-6 warm side vapor retarder ("R19 int-IWSP")

MASONRY BLOCK WALL WITH INTERIOR R-19 BATT INSULATION / 2-mil PA-6
WARM-SIDE VAPOR RETARDER AND AN INTERIOR WSP:

RELATIVE HUMIDITY TIME SERIES

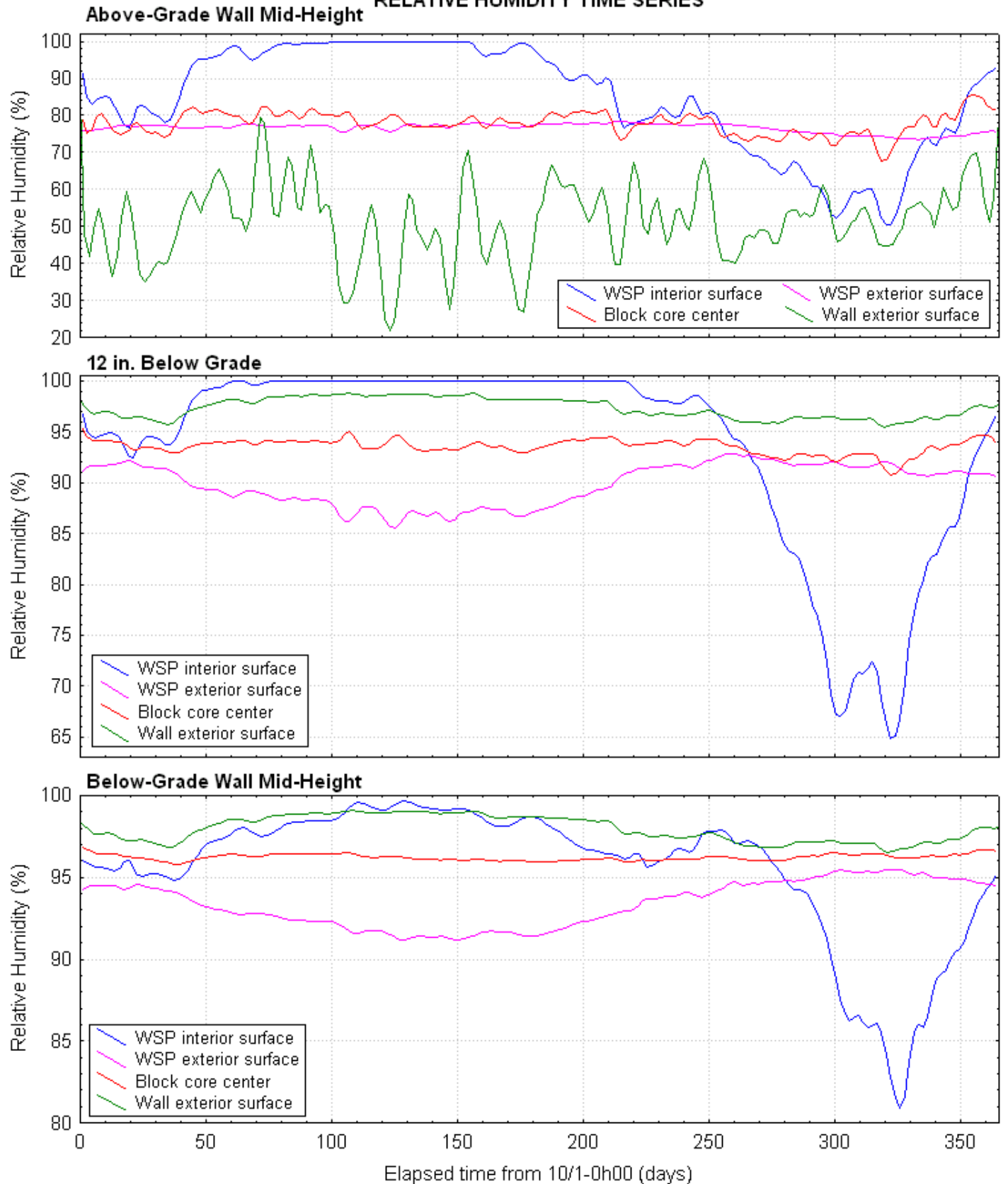

Figure B.7

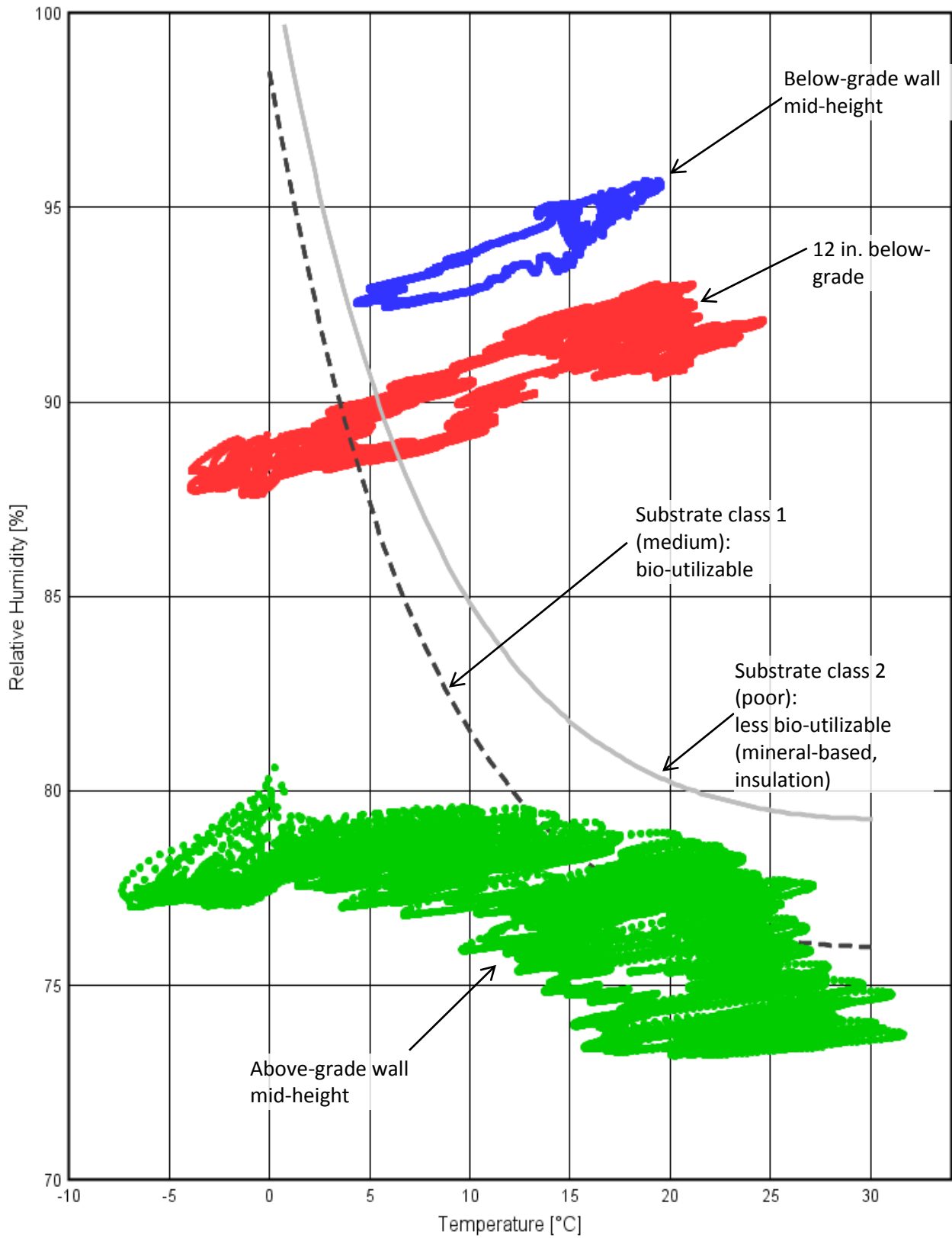

Figure B.8 Masonry block wall with interior R-19 batt insulation / 2 mil. PA-6 warm side vapor retarder and an interior WSP: temperate/relative humidity mold isopleths for the cavity between the wall and the WSP



Figure B.9 Condition of an interior WSP on a masonry block wall with no interior insulation and exterior damp-proofing to grade in a well-draining sandy soil after a period of persistent rain (15 years after construction).

**MASONRY BLOCK WALL WITH INTERIOR R-19 BATT INSULATION / 2-mil PA-6 WARM-SIDE
VAPOR RETARDER AND AN INTERIOR WSP:
DRYING MOISTURE CONTENT TIME SERIES FOR INITIALLY SATURATED
INTERIOR SHELL**

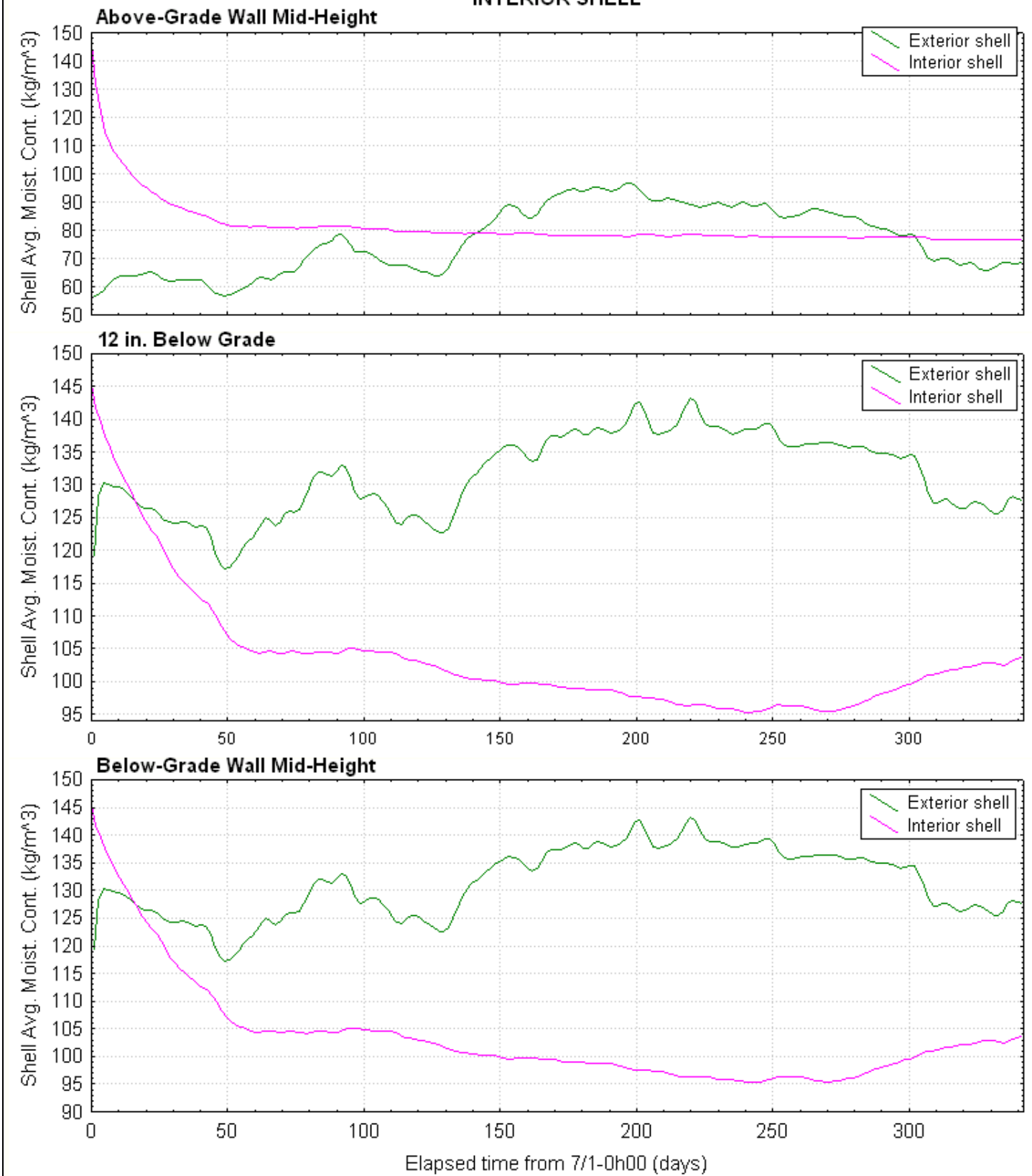

Figure B.10

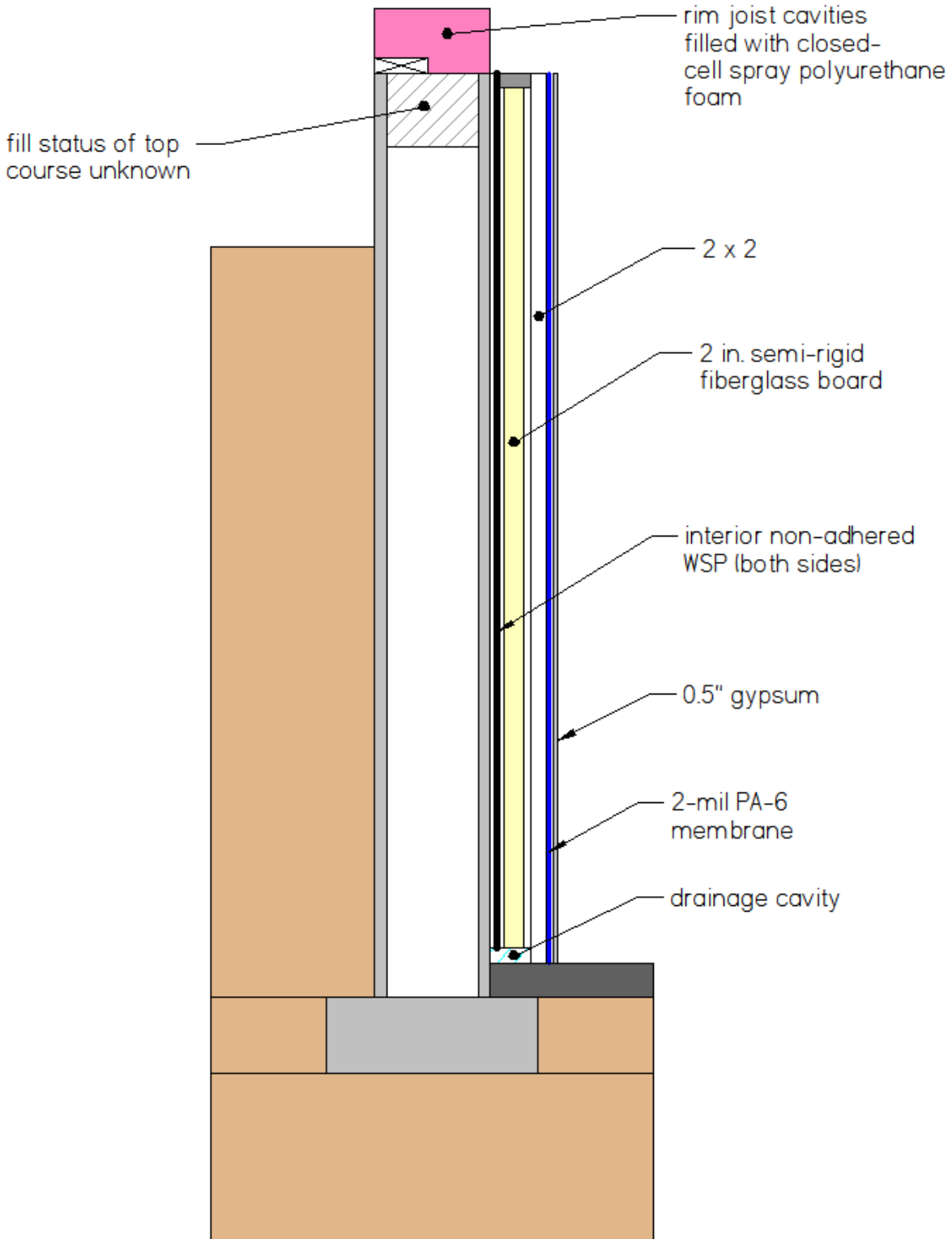

Figure B.11 Retrofit double-sided non-adhered interior WSP + interior 2 in. semi-rigid fiberglass insulation + 2-mil. PA-6 warm side vapor retarder

**MASONRY BLOCK WALL WITH INTERIOR R-8 SEMI-RIGID FIBERGLASS
BOARD INSULATION / 2-mil PA-6 WARM SIDE VAPOR RETARDER
AND NON-ADHERED INTERIOR WSP**

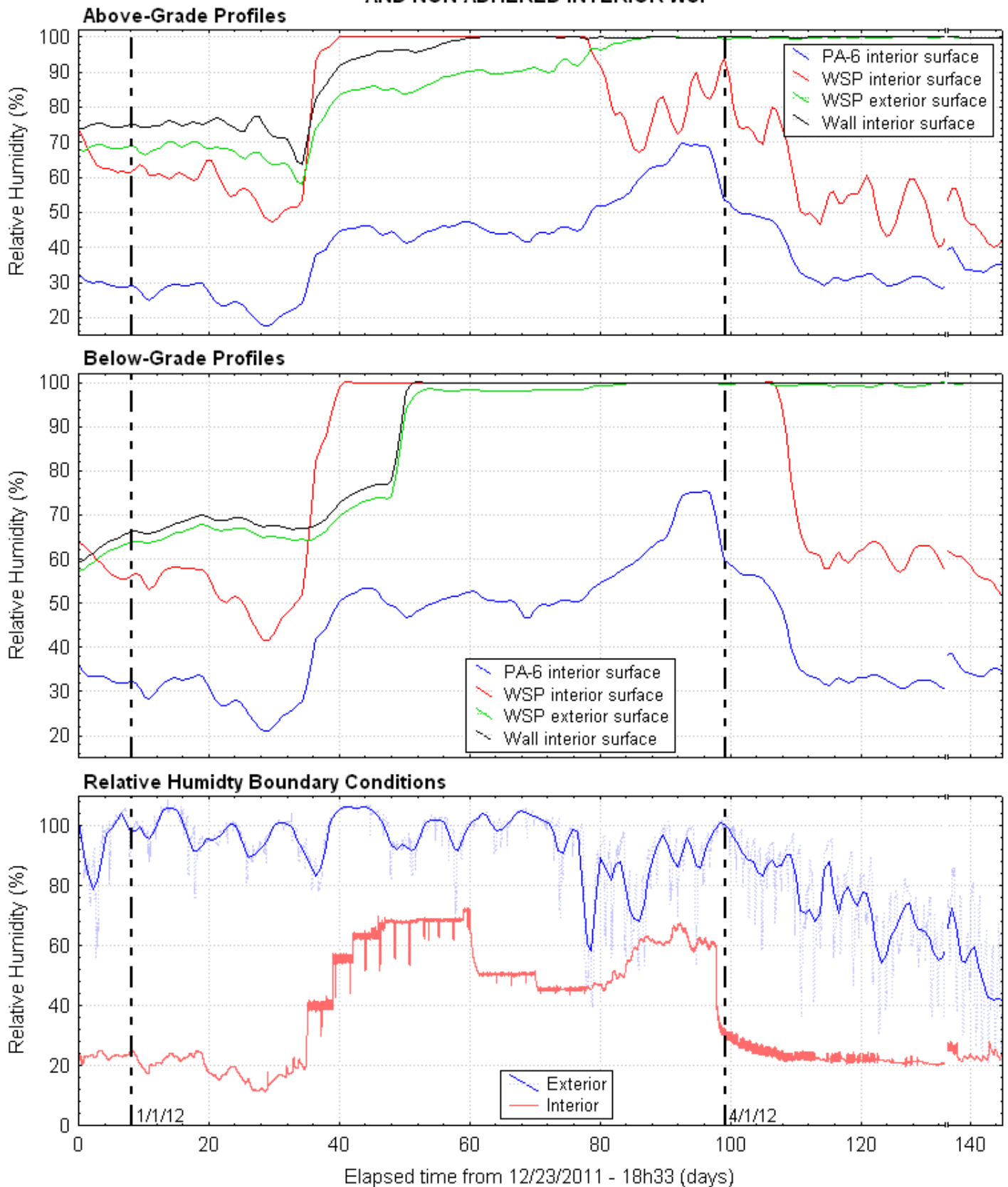

Figure B.12

**MASONRY BLOCK WALL WITH INTERIOR R-8 SEMI-RIGID FIBERGLASS BOARD INSULATION / 2-mil PA-6 WARM SIDE VAPOR RETARDER AND NON-ADHERED INTERIOR WSP:
ABOVE-GRADE CONDENSATION PERFORMANCE**

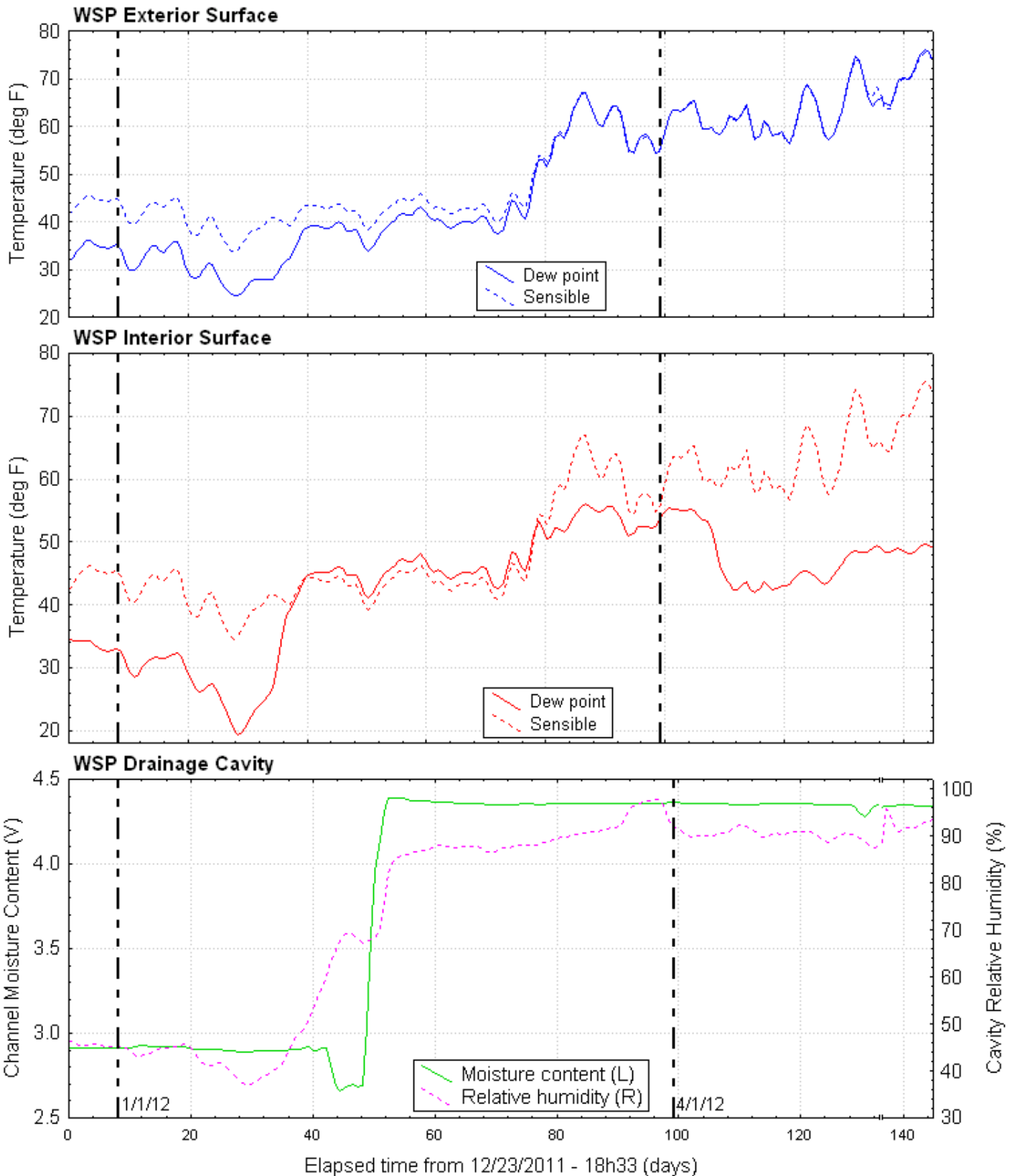

Figure B.13

**MASONRY BLOCK WALL WITH INTERIOR R-8 SEMI-RIGID FIBERGLASS BOARD INSULATION / 2-mil
PA-6 WARM SIDE VAPOR RETARDER AND NON-ADHERED INTERIOR WSP:
BELOW-GRADE CONDENSATION PERFORMANCE**

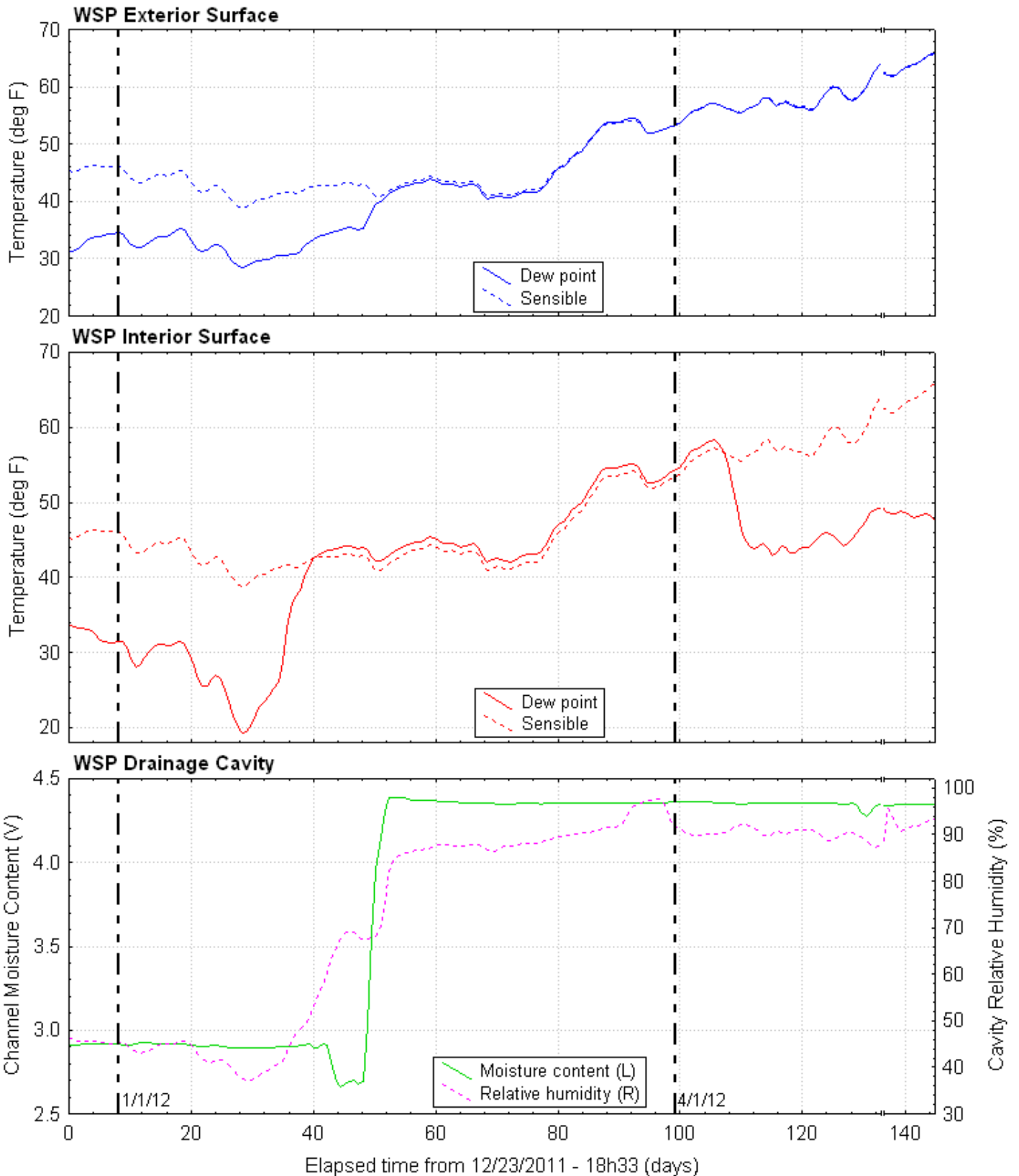

Figure B.14

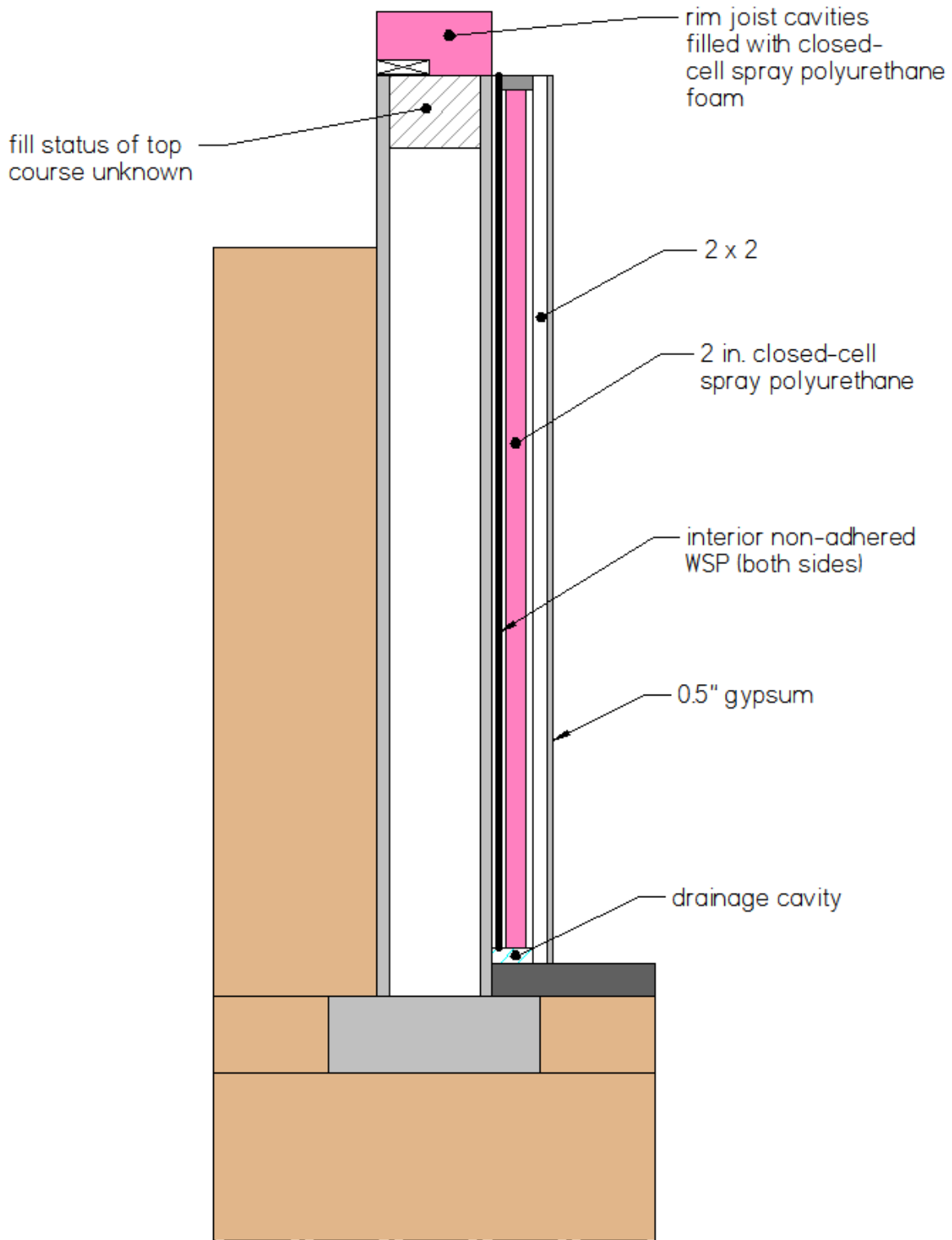

Figure B.15 Retrofit double-sided non-adhered interior WSP + interior 2 in. closed-cell spray polyurethane insulation

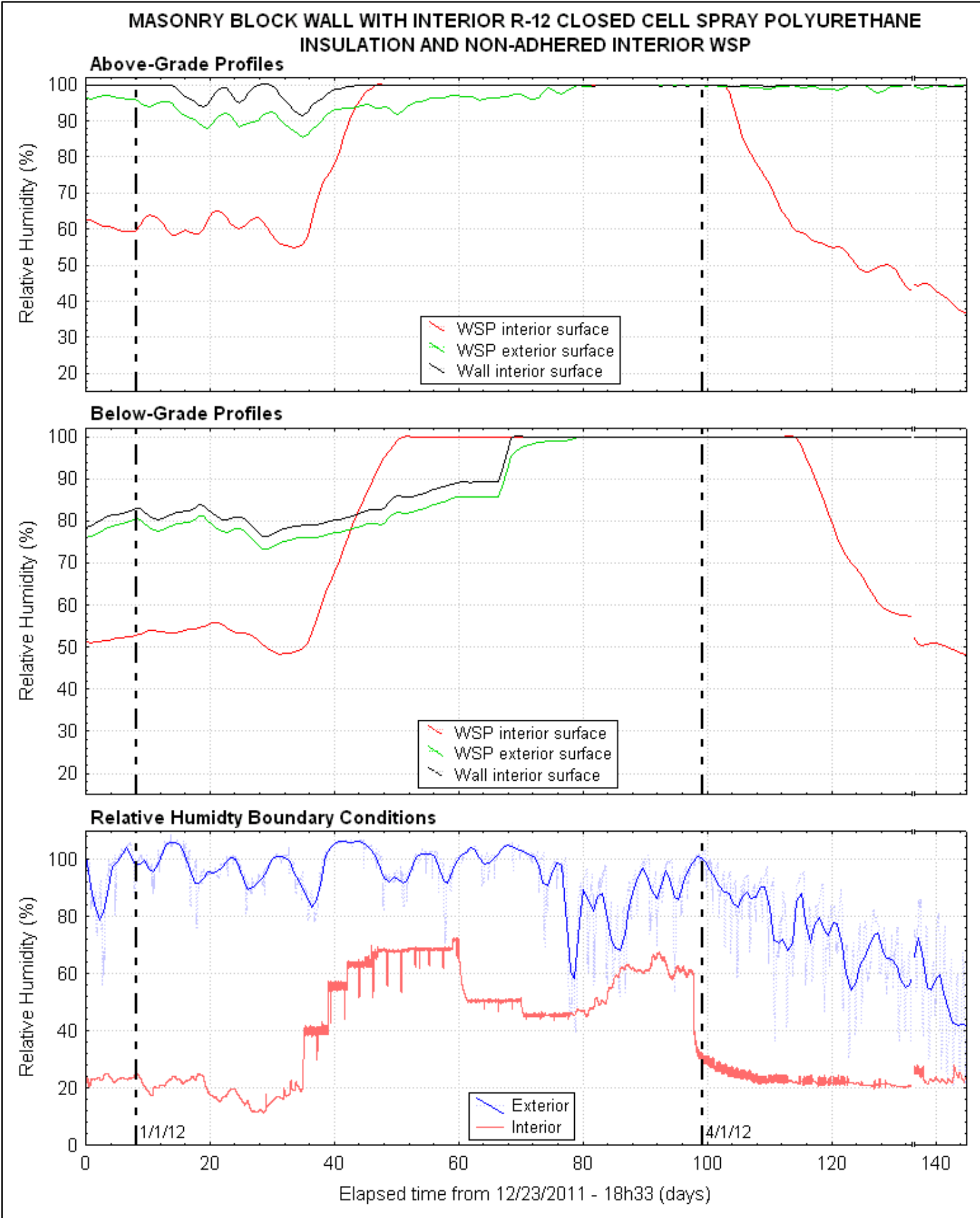

Figure B.16

B.5 Masonry Block Wall with an Exterior Adhered WSP, R-19 Cavity Insulation and a 2-mil. PA-6 Warm Side Vapor Retarder

In this case (Figure B.17), the interior WSP was relocated to the exterior of the CMU wall and simulated as an adhered WSP as is common practice. The interior R-19 cavity insulation system (as defined in the previous case) was placed flush against the wall as a practical worst case even though the previous 2005 review recommended that the stud frame be offset by 1 in. from the wall surface.

The condensation results shown in Figure B.18 reveal a very interesting result, namely, that the exterior wall surface (now on the interior of the WSP) experienced condensation 12 in. below grade from 2/25 through 5/5, about 2.33 months. No condensation occurred above grade despite the colder temperatures there. Further, no condensation was evident on the surfaces of the block cores (in equilibrium with the core RH) or on the wall interior surface.

The simulated absence of condensation on the interior wall surface is clearly incorrect⁵ as shown by the experimental data reported in Figures B.19 through B.21 (collected at the Foundation Test Facility (Goldberg, 2006)). The experimental system was the same as that of Figure B.17 with the following differences:

- the insulation consisted of R-13 batts in a 2 x 4 stud frame (not R-19 in a 2 x 6 frame)
- there was no interior gypsum wall board on some of the test panels
- during the heating season, the interior relative humidity boundary condition did not exceed 55 %, whereas the ASHRAE 160 interior RH boundary condition shown in Figure B.1 peaked at values in excess of 60 %.

Thus the experimental data reflects a less onerous condensation environment on the wall interior surface than in the simulation in terms of warmer surface temperatures (higher insulation thermal conductance) and a lower interior RH boundary condition, but a more onerous environment due to the absence of gypsum that increased the net permeance of the assembly. Thus, on balance, the condensation environments are comparable. In this context, as revealed by Figure B.19, the wall surface on the east facing wall was wet from early November through the middle of March, while on the south facing wall, the wetting period was from mid-November through the end of February. The south facing wall was drier owing to the solar gain on the above-grade portion of the wall. When the system was dismantled in mid-February, Figures B.20 and B.21 clearly show that the walls were wet.

However, based on the experimental data alone, it is clear that the wetting/drying behavior is compliant with the performance criteria for fiberglass cavity fill insulation. Thus owing to the minor difference in the permeance between R-13 and R-19 batts, it is reasonable to infer that it is compliant for R-19 fiberglass batts as well. However, it is crucial to understand why the system is compliant and under what limitations this compliance is achieved. The key factor is that the CMU wall surface acts as a moisture storage system, safely absorbing and storing the condensed vapor transported through the warm-side vapor retarder during the heating season and then drying out through the rest of the year. However, the water absorption capacity is limited and is a function of the above-grade exposed wall height. From Figures B.20 and B.21, an above-grade wall height of 18 in. yielded a maximum rundown to 41 in. from the top of the wall (about 51 in. above the slab). So the questions arise as to (a) how much above-grade

⁵ This lack of validity of the simulation results has been the driver for a new research project at the University of Minnesota that will seek to validate the WUFI-2D/ESL methodology against high quality experimental data including a full characterization of the soil moisture boundary conditions.

exposure is allowable before the wall surface is wetted down to the slab, and (b) would poured concrete walls show different rundown behavior?

Based on a simple linear extrapolation that is not completely unreasonable in this case, a 40 in. above-grade wall height would appear to be possible for a wall built with standard CMU's. Owing to the presence of a "skin" on the surface of poured concrete walls, it is possible that the surface absorption would be reduced leading to a larger amount of rundown. Thus as a prudent measure, it seems reasonable to limit the above grade exposure for both CMU and poured concrete walls to no more than 3 ft in order to avoid the possibility of rundown to the interior slab. However, there is no experimental data to confirm this approach, and as discussed, it cannot be evaluated at present by simulation.

The exterior CMU shell condensation phenomenology 12 in. below-grade shown in Figure B.18 warranted further investigation. An examination of the data revealed that condensation occurred from 12 in. below grade to grade itself before disappearing above grade. Figure B.22 is a plot of the average CMU exterior shell temperature and RH at a below-grade depth of 1.75 in. approximating the most severe condensation condition. The data show that between day 121 and day 205, the exterior shell was at vapor saturation, while the average temperature was intermittently below freezing during that period. Of further significance is the absence of moisture equilibrium during year 2 of the simulation with the average exterior shell RH increasing from 85.3 % to 91.1 % over the year. Based on the simulation's under-prediction of the interior wall surface condensation phenomenology discussed above, it is reasonable to expect that the surface condensation was being under-predicted on the exterior shell as well.

In order to assess the impact of the 4 freeze/thaw cycles experienced by the exterior shell during this 2.8 month period, it is necessary to review the basic phase change physics operating in CMU pores as mentioned previously in Section B.1.2. Firstly, since porous materials like concrete contain a wide distribution of pore sizes, freezing occurs over a range of temperatures, known as the freezing point depression (for example, Olsen, 1984). In particular, the freezing point decreases with decreasing pore size. Typically, a value of -1°C is used as a freezing onset average for concrete aggregates and this value is shown on Figure B.22 as the freeze/thaw temperature limit. The mechanics of the freeze/thaw process are quite complex (Litvan, 1980) so that even when a CMU undergoes a freeze/thaw cycle, provided that the process is slow enough (low irreversibility), structural damage (spalling, cracking, etc) need not occur. The higher the magnitude of the step change at the freezing temperature for a given pore vapor pressure, the greater the irreversibility and the higher the probability of structural damage.

Therefore, Figure B.22 does not demonstrate that freeze/thaw damage will occur under the simulated temperature and RH conditions, only that a potential exists in the following circumstances:

- the equilibrium moisture content of the masonry block increases as the system tends to hygric equilibrium so that the saturation ratio exceeds the critical ratio of 0.9168 (as noted, the simulation results likely under-predict the moisture content).
- the freezing and thawing temperature gradients are high enough to produce significant irreversibilities.

There are in essence at least two approaches to minimizing this potential. The first is to design the CMU concrete mix to yield material characteristics (pore size, etc) that minimize the potential for spalling and cracking under freeze/thaw conditions. The National Concrete Masonry Association (NCMA, 2011) recommends that CMU's be tested for freeze/thaw

durability in MN (and other cold climates) using ASTM C1262 (“Standard Test Method for Evaluating the Freeze-Thaw Durability of Dry-Cast Segmental Retaining Wall Units and Related Concrete Units”) but that the results be evaluated with more lenient criteria than those in Section 5.2 (“Freeze-Thaw Durability”) of ASTM C1372. In particular, the NMCA recommends that that: “(1) The weight loss of each of 5 specimens at the conclusion of 20 cycles should not exceed 1 % of its initial weight; or (2) The weight loss of each of 4 of the 5 test specimens at the conclusion of 30 cycles should not exceed 1.5 % of its initial weight.”

The second approach seeks to remove the vapor source leading to condensation in the block cores and this approach is explored in the next section.

However, in the light of the above discussion and that in Section B.4, it is necessary to add an additional element to the performance criteria that addresses the freeze/thaw structural issue. The most prudent approach is to require that the water saturation ratio in the structural wall components not exceed the critical water saturation ratio at the freezing temperature for the prevailing vapor pressure in the pores of the material. This would ensure a material-neutral compliance mechanism that may be preferable to requiring an ASTM C1262 test for CMU’s only and also would be applicable to wood foundations.

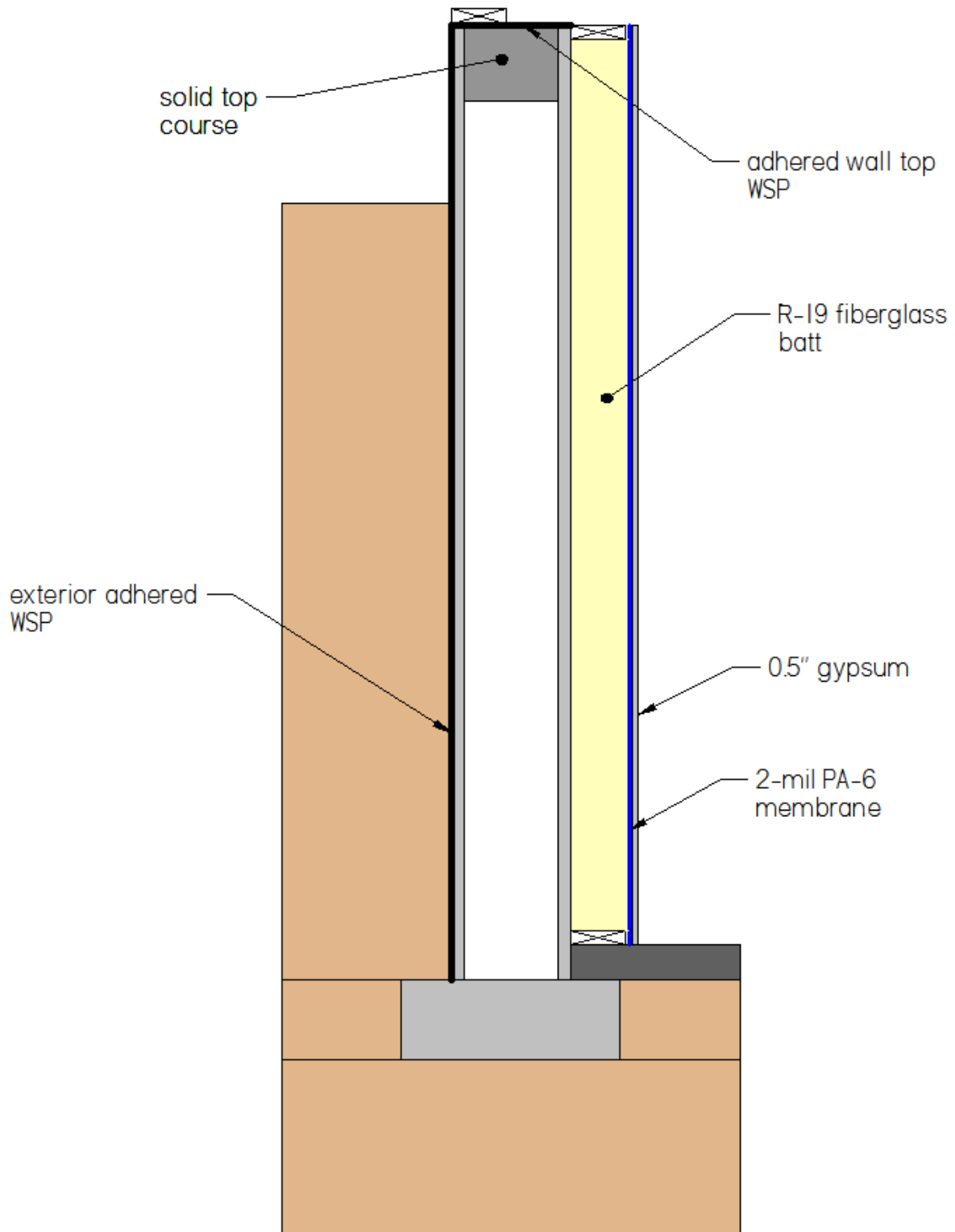

Figure B.17 Base + exterior and wall top adhered WSP + interior R-19 cavity insulation + 2-mil. PA-6 warm side vapor retarder ("R19 int-EWSP")

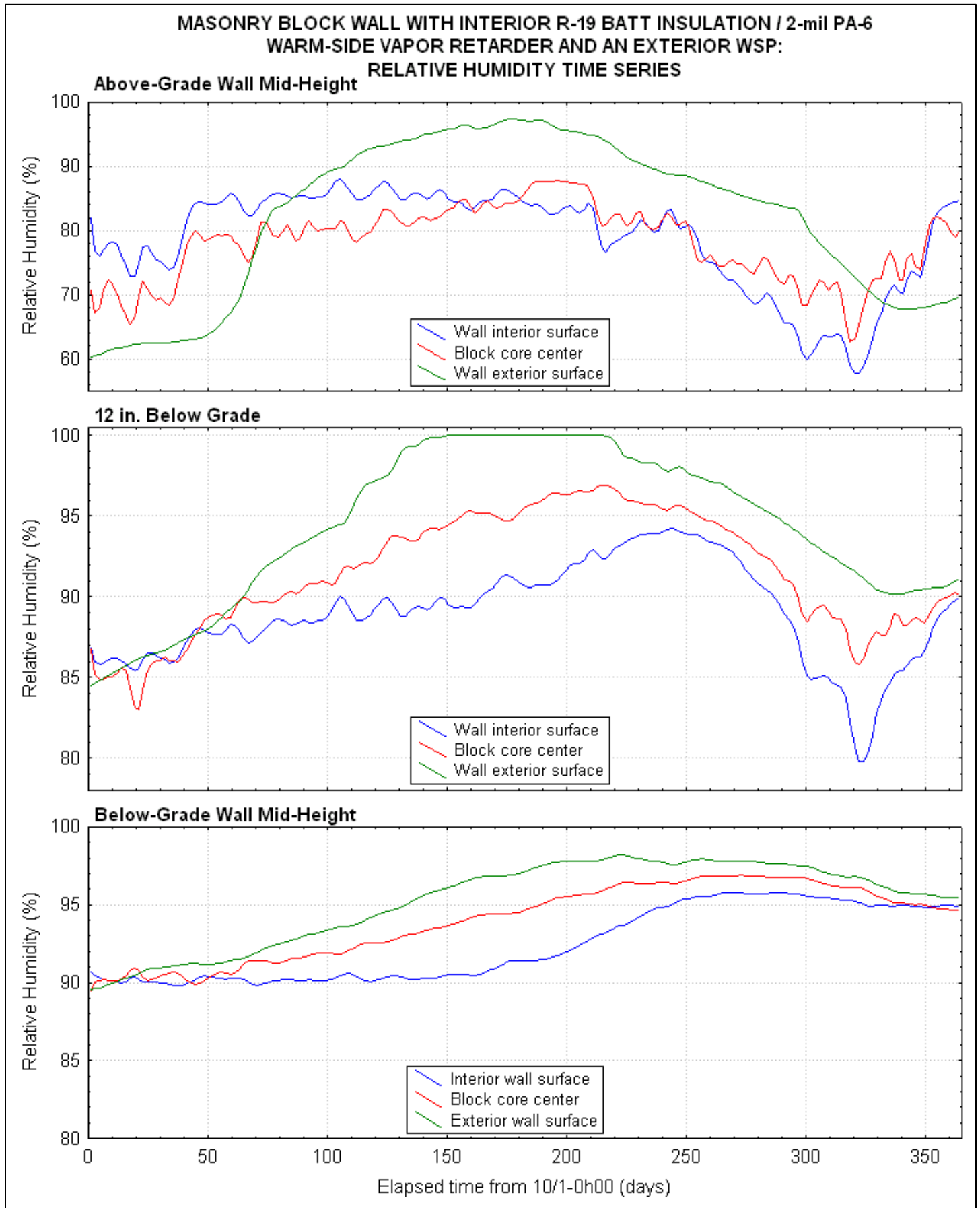

Figure B.18

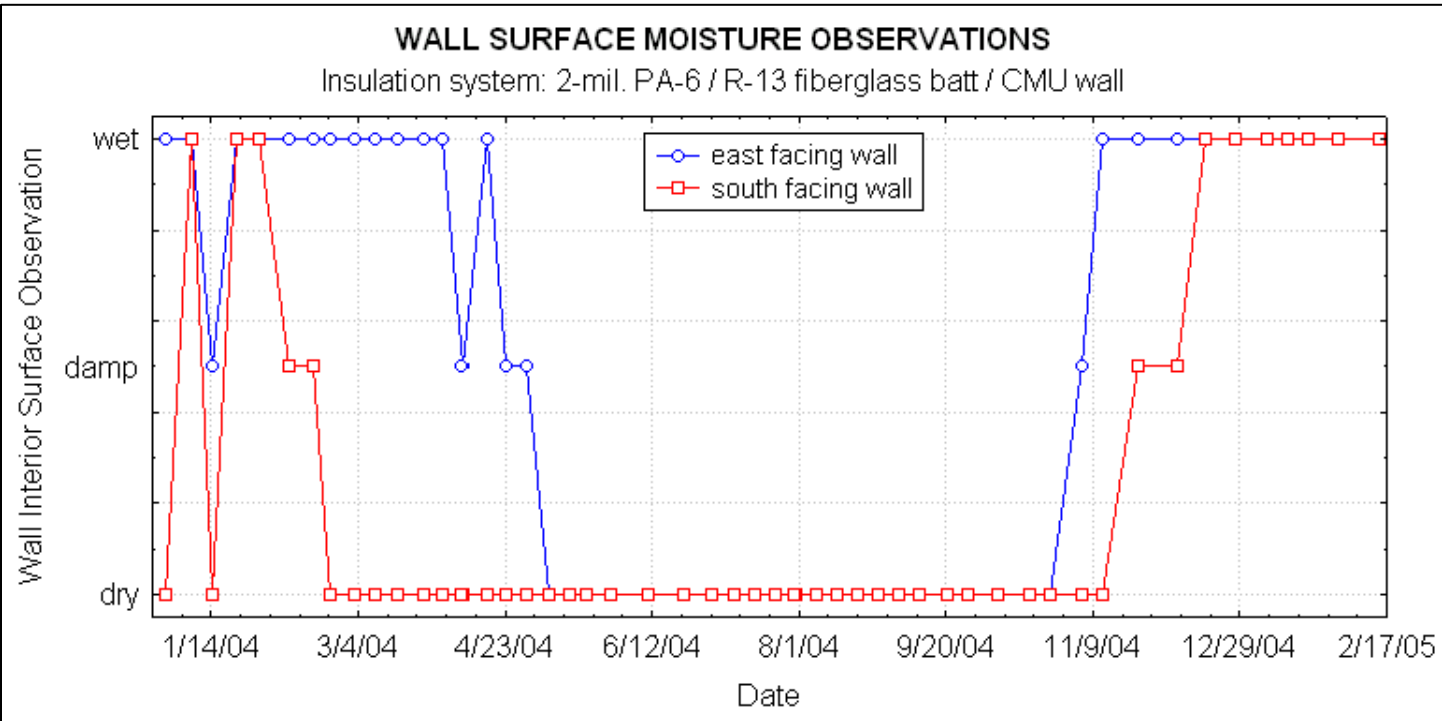

Figure B.19 Surface observations for a section of wall extending from 12 in. above-grade to 4 in. below grade

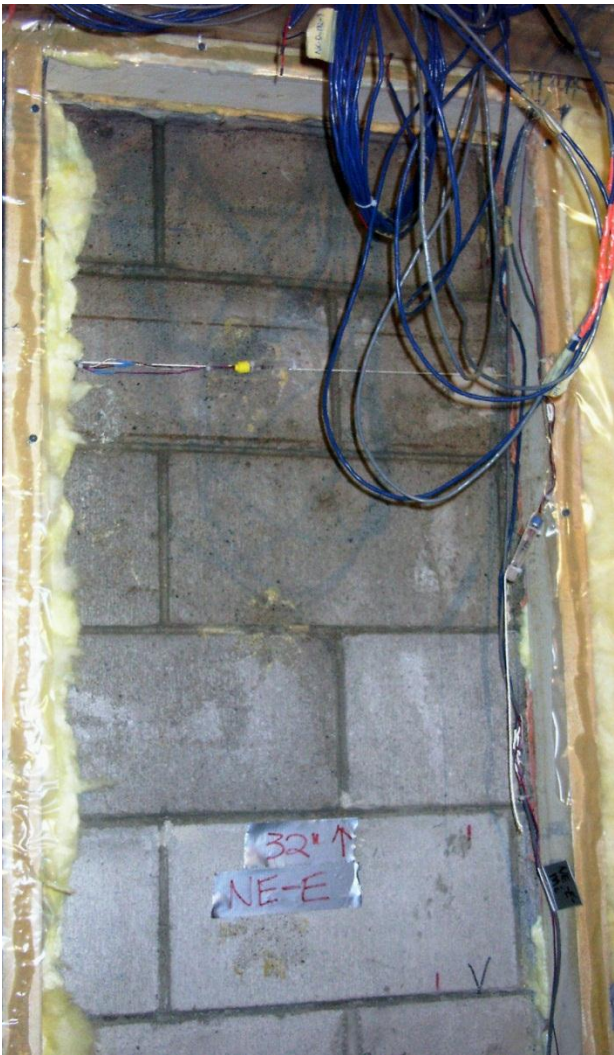

Figure B.20 Surface of the east-facing wall at tear down on 2/14/05



Figure B.21 Surface of the south-facing wall at tear down on 2/14/05

MASONRY BLOCK WALL WITH INTERIOR R-19 BATT INSULATION / 2-mil PA-6
WARM-SIDE VAPOR RETARDER AND AN EXTERIOR WSP:
EXTERIOR SHELL THERMAL/STRUCTURAL INTERACTION

1.75 in. Below Grade

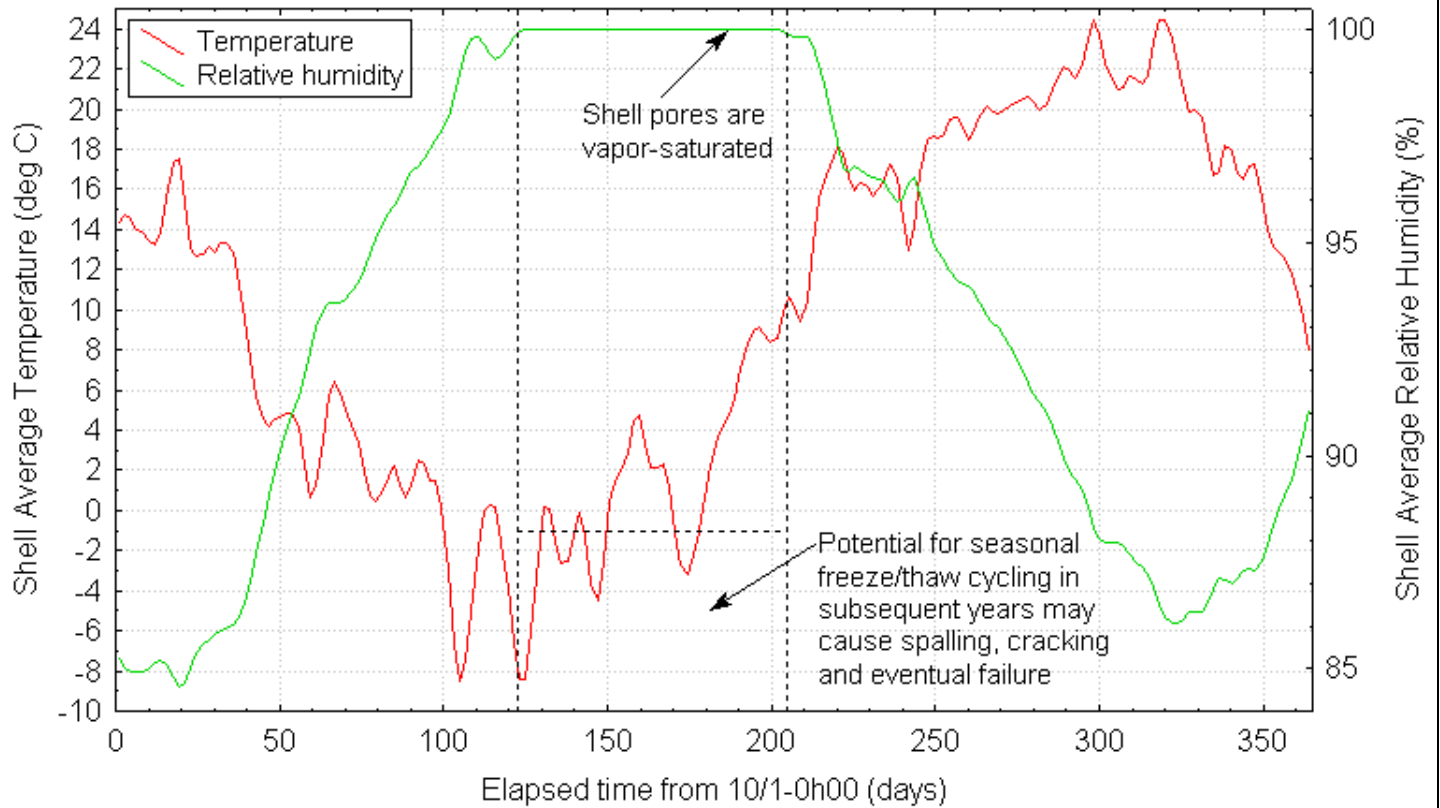

Figure B.22

B.6 Masonry Block Wall with a Wall Exterior Adhered and Footing Top WSP, R-19 Cavity Insulation and a 2-mil. PA-6 Warm Side Vapor Retarder

Other than the interior surface, the only other source of cavity vapor in Figure B.17 is the upper surface of the footing. Thus following the recommendation of the previous review (Goldberg and Huelman, 2005), a WSP is included above the footing in Figure B.23.

The maximum wall exterior surface RH 12 in. below grade of less than 85% was significantly less than that of the vapor saturation condition of Figure B.18. A comparison of Figure B.25 against Figure B.22 demonstrates that the potential for freeze/thaw structural damage between day 121 and day 205 had been eliminated by the inclusion of a WSP above the footing. Further, the maximum block core RH was reduced from 97 % in Figure B.18 to less than 83 % in Figure B.24. Thus given the likelihood of the simulation under-predicting the amount of condensation on the block core surfaces, these data provide conclusive confirmation that extending the WSP from beneath the slab to connect with the wall exterior WSP in such a way as to isolate the block cores from the soil moisture source, offers a major improvement in the durability of the wall system and thus will be included in the recommendations for the prescriptive rules.

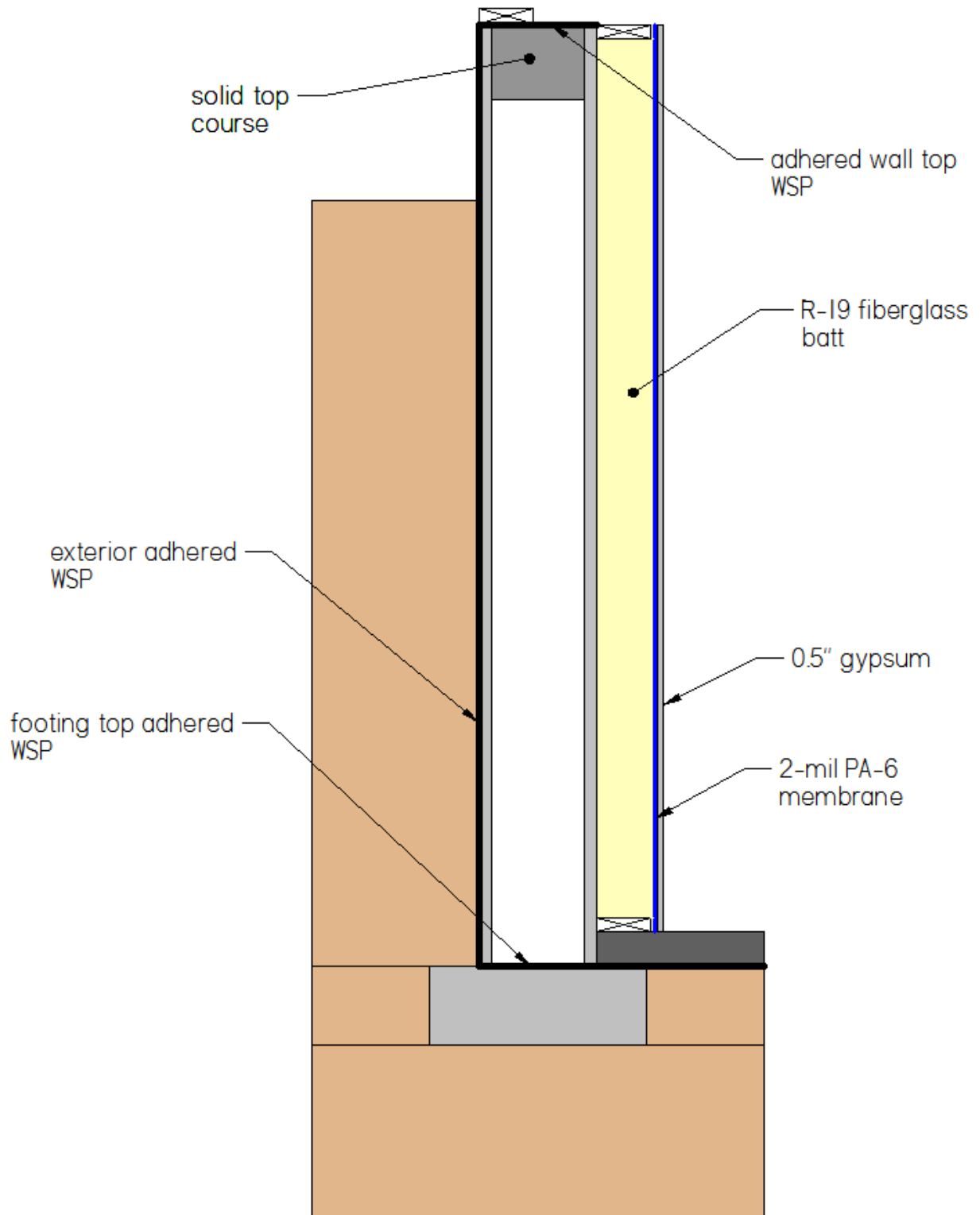

Figure B.23 R19 int-EWSP + footing top adhered WSP

MASONRY BLOCK WALL WITH INTERIOR R-19 BATT INSULATION / 2-mil PA-6
 WARM-SIDE VAPOR RETARDER, WALL EXTERIOR AND FOOTING TOP WSP:
 RELATIVE HUMIDITY TIME SERIES

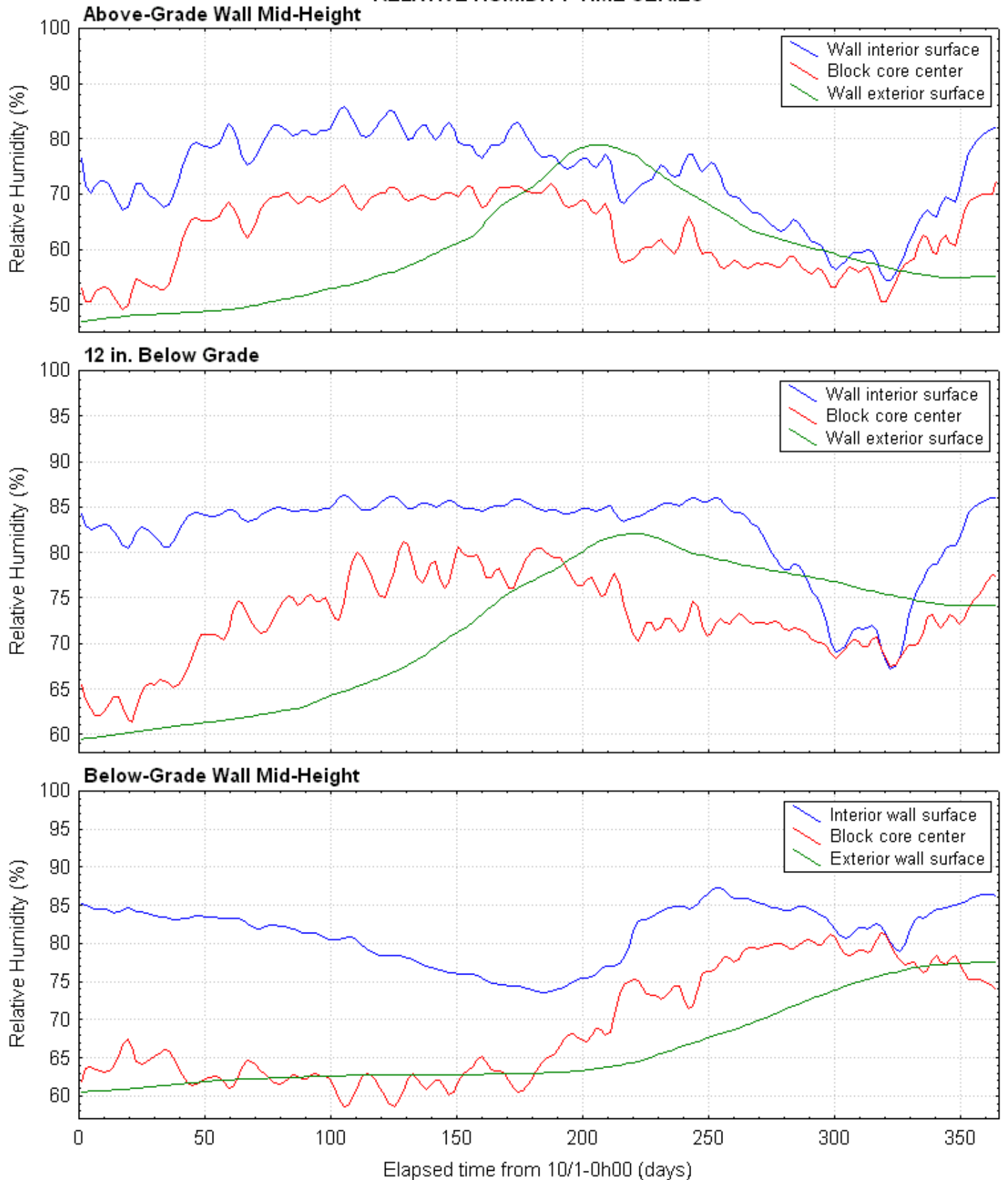

Figure B.24

MASONRY BLOCK WALL WITH INTERIOR R-19 BATT INSULATION / 2-mil PA-6
WARM-SIDE VAPOR RETARDER, WALL EXTERIOR AND FOOTING TOP WSP:
RELATIVE HUMIDITY TIME SERIES

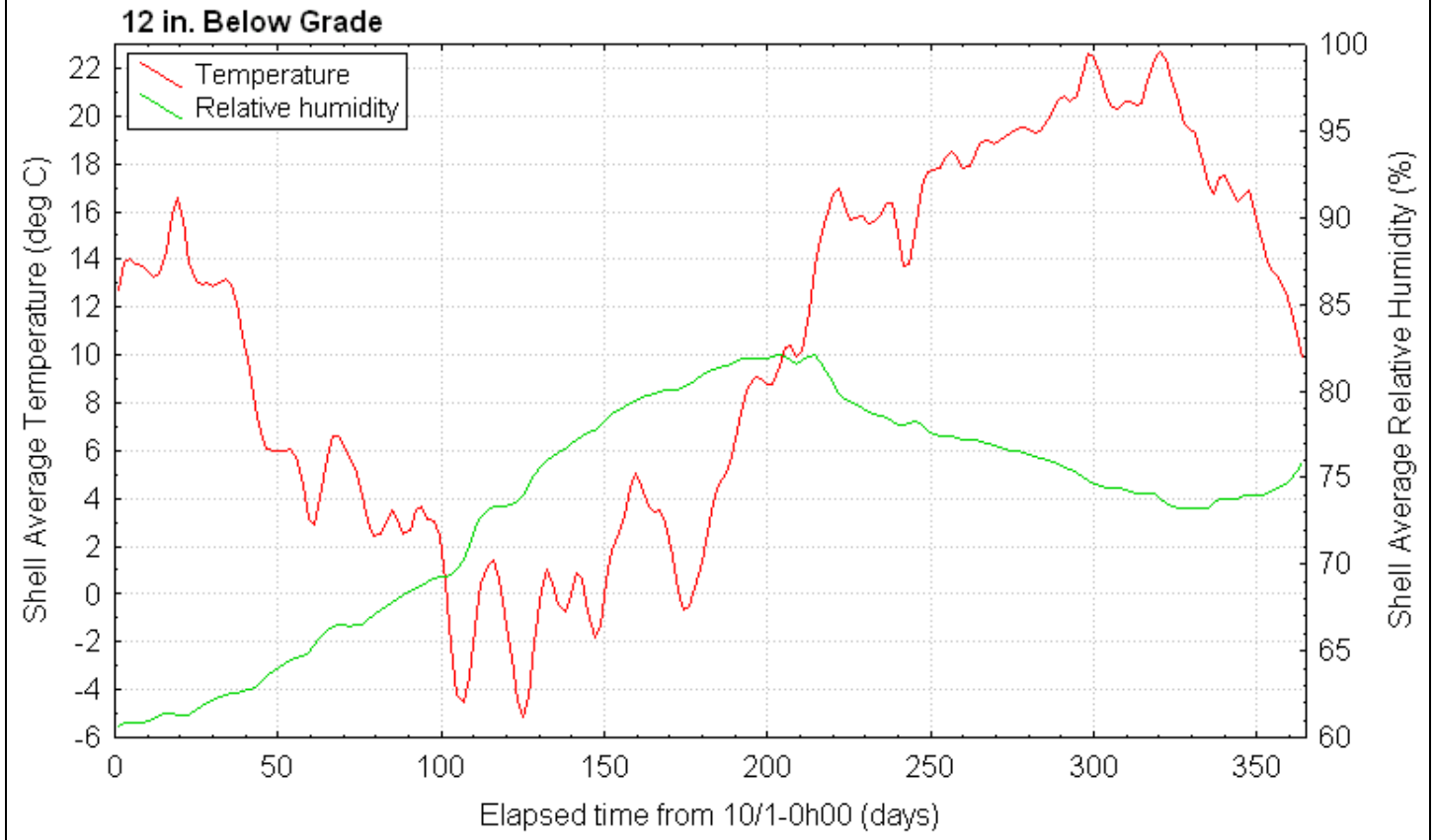

Figure B.25

B.7 Masonry Block Wall with an Interior Non-Adhered WSP, Exterior Adhered WSP to Grade, R-19 Cavity Insulation and a 2-mil. PA-6 Warm Side Vapor Retarder

Referring back to Figure B.23, another approach to isolating the masonry block cores is to encase the wall in an inverted “U” shaped WSP, that is with an interior, exterior and a wall-top WSP. This approach was evaluated in two steps. In the first step, shown in Figure B.26, the exterior WSP was extended to grade only for the purpose of determining whether the exposed wall top only would allow drying of a wetted wall to the exterior (drying of a wetted interior shell without any WSP was demonstrated in Figure B.10). Clearly it is essential to install a WSP below grade on a CMU wall to prevent bulk water seepage from the soil into the wall system. So evaluating the drying performance under these conditions is essential.

However, in this case, it was assumed that the exterior shell also was vapor saturated at the beginning of the simulation on 7/1 on the grounds that if the wall was wetted, then the exterior WSP would prevent moisture equilibration with the soil and so the blocks would remain wet with the only potential for drying through the exposed upper wall and the top of the footing.

The results of this test are shown in Figure B.27. The above-grade portion of the wall dried to a moisture content of 80 kg/m^3 within 130 days (compared with 50 days in Figure B.10). Below grade, the moisture contents reached 105 kg/m^3 within 170 days (compared with 50 days in Figure B.10). Thus it is clear that adding an exterior WSP to grade significantly reduces the drying potential to the exterior in the event that the wall becomes wet as a result of bulk water intrusion or excessive vapor influx to the cores.

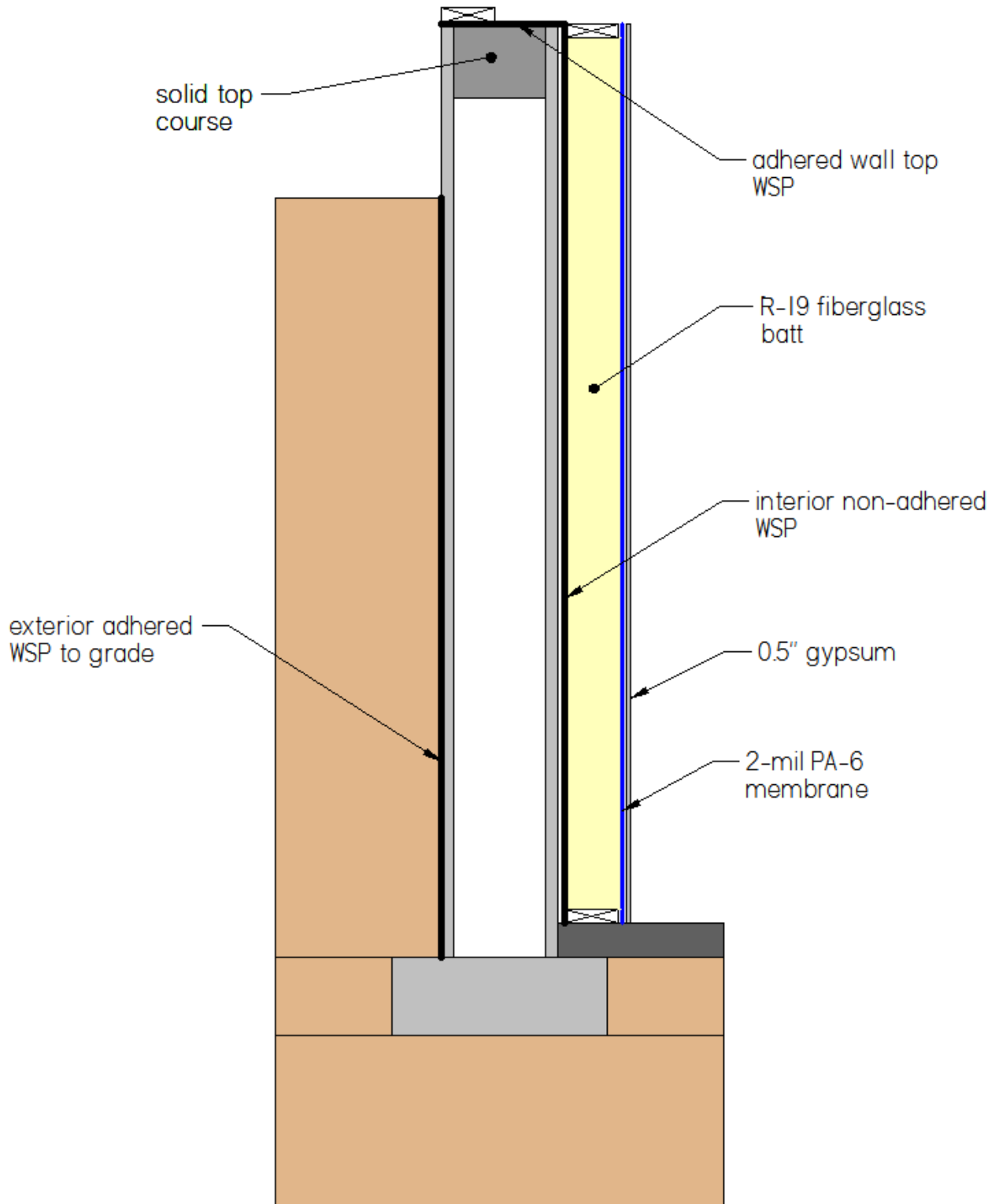

Figure B.26 R19 int-IWSP + exterior adhered WSP to grade

**MASONRY BLOCK WALL WITH INTERIOR R-19 BATT INSULATION / 2-mil PA-6 WARM-SIDE VAPOR RETARDER, INTERIOR WSP AND EXTERIOR WSP TO GRADE:
 DRYING MOISTURE CONTENT TIME SERIES FOR INITIALLY SATURATED
 INTERIOR AND EXTERIOR SHELLS**

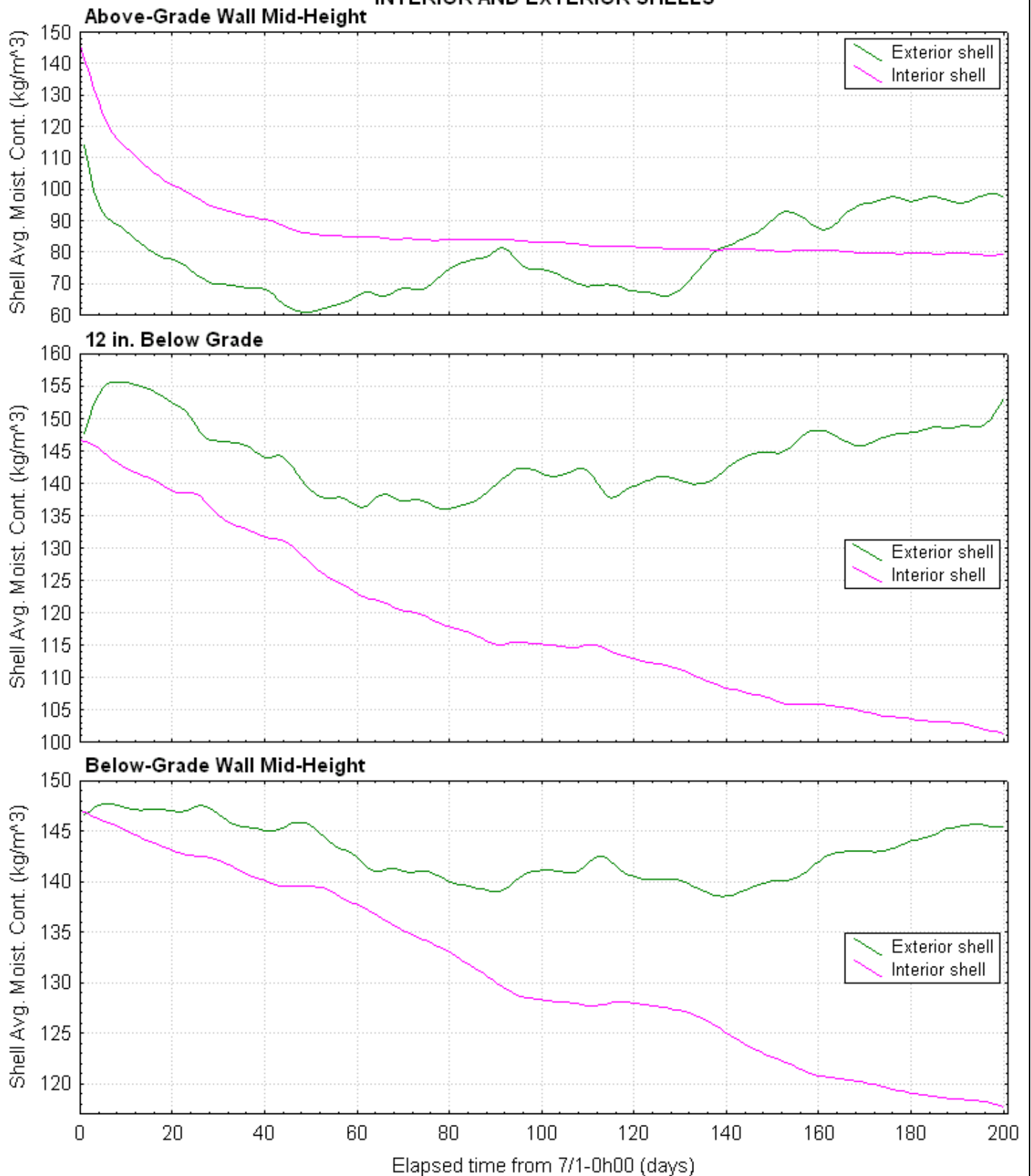

Figure B.27

B.8 Masonry Block Wall with an Interior Non-Adhered WSP, Exterior Full Wall Adhered WSP, R-19 Cavity Insulation and a 2-mil. PA-6 Warm Side Vapor Retarder

The case with the full inverted “U” WSP is shown in Figure B.28. This case is essentially the same as that of Figure B.6 with the addition of a full wall exterior WSP.

The condensation surface results are shown in Figure B.29. The condensation performance on the interior of the WSP was the same as that of Figure B.7 as expected from the hygric decoupling effect of the interior WSP. The RH in the masonry block cores was generally lower with the added exterior WSP as expected from the decrease in source moisture strength, and the RH was lower in the drainage gap as well. However, the magnitude of the decrease was lower than might be expected indicating the strength of the vapor coupling to the soil through the footing.

Figure B.29 still shows that the exterior wall surface reaches vapor saturation 12 in. below grade from day 180 through day 195, but, considerably reduced with respect to Figure B.22 as a result of the removal of the basement interior moisture source. Figure B.30 shows the potential for freeze/thaw damage when the wall system reaches hygric equilibrium continued to exist.

This WSP design did not perform nearly as well as that of Figure B.23 with the footing top WSP, even with the wall coupled to the basement interior moisture source. Again this shows the strength of the moisture coupling through the footing and the advantage of hygrically isolating the footing to decouple the block cores from the soil compared with the alternative inverted “U” WSP system.

Finally, the inverted “U” WSP approach only allows drying through the top of the footing, thus reasonably allowing the inference of worse drying performance than shown in Figure B.27 with an exposed wall top. Draining the cores to a footing drain tile via holes drilled into cores of the bottom course does, of course, drain any bulk water from the cores but at the same time increases the vapor coupling between the soil and the cores. Thus given the sensitivity of the system to soil coupling through the footing, this would exacerbate the drying performance.

Thus based on these data, the inverted “U” WSP design cannot be recommended as a prescriptive option.

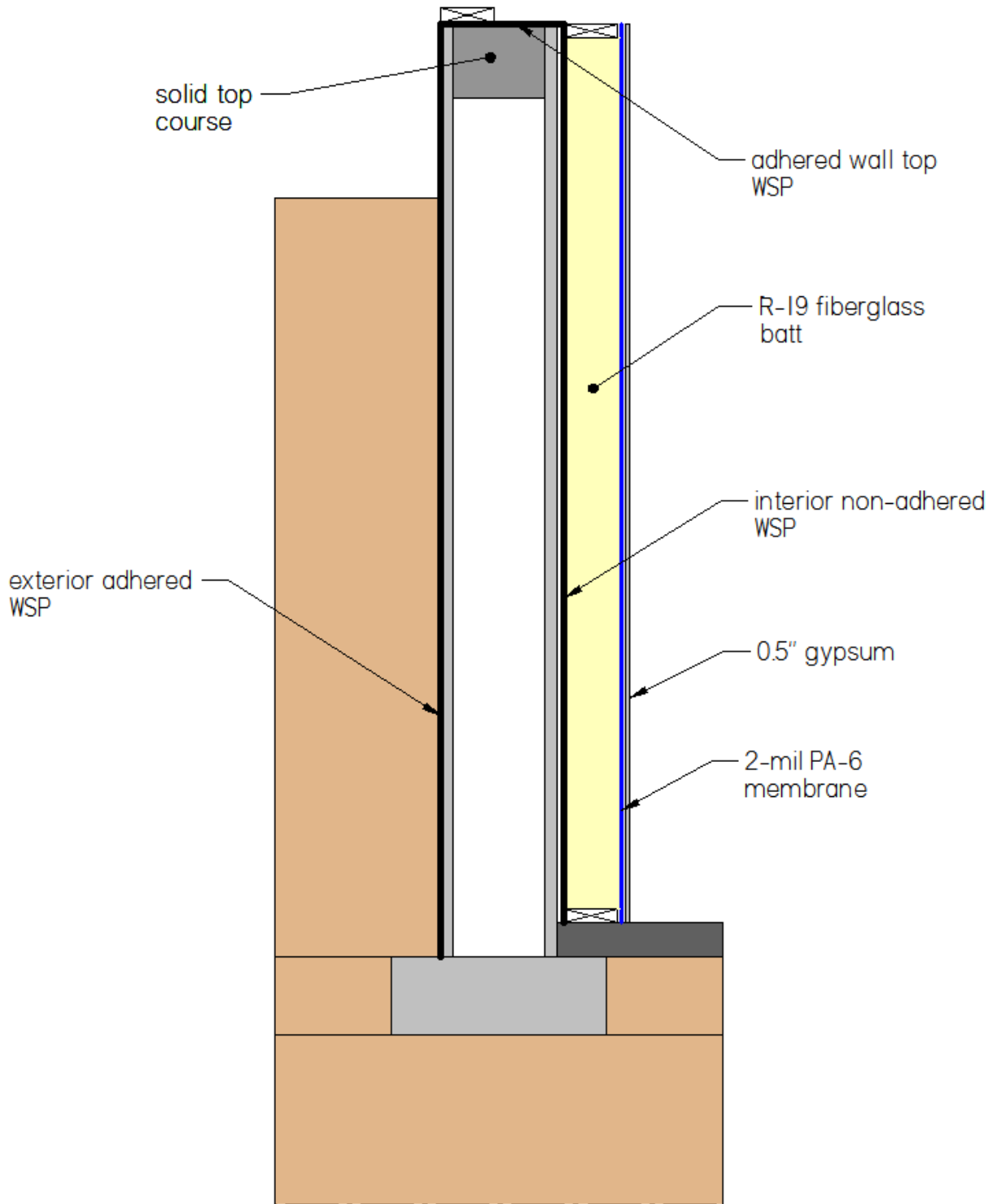

Figure B.28 R19 int-IWSP + exterior full-wall adhered WSP

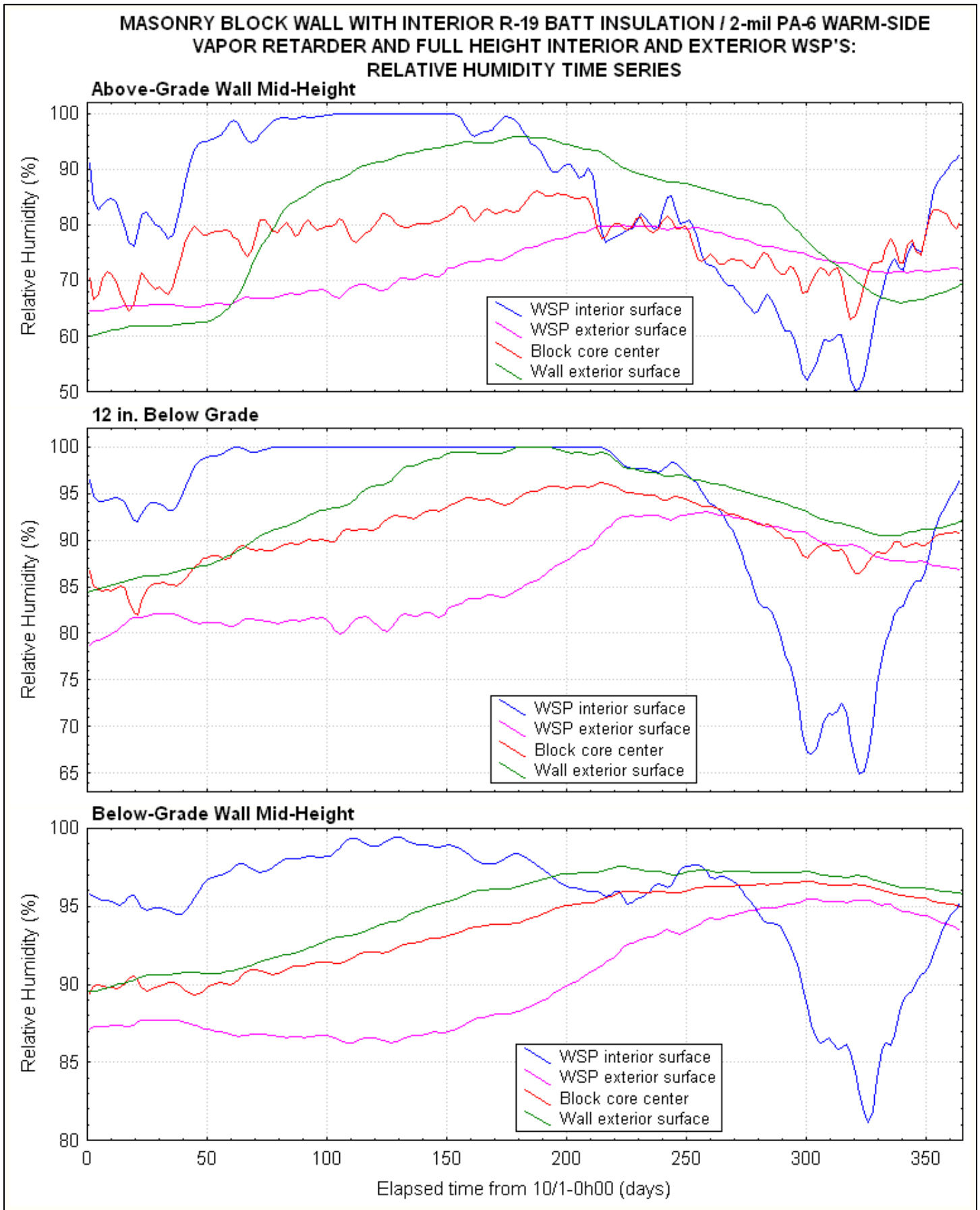

Figure B.29

**MASONRY BLOCK WALL WITH INTERIOR R-19 BATT INSULATION / 2-mil PA-6 WARM-SIDE VAPOR RETARDER AND FULL HEIGHT INTERIOR AND EXTERIOR WSP'S:
EXTERIOR SHELL THERMAL/STRUCTURAL INTERACTION**

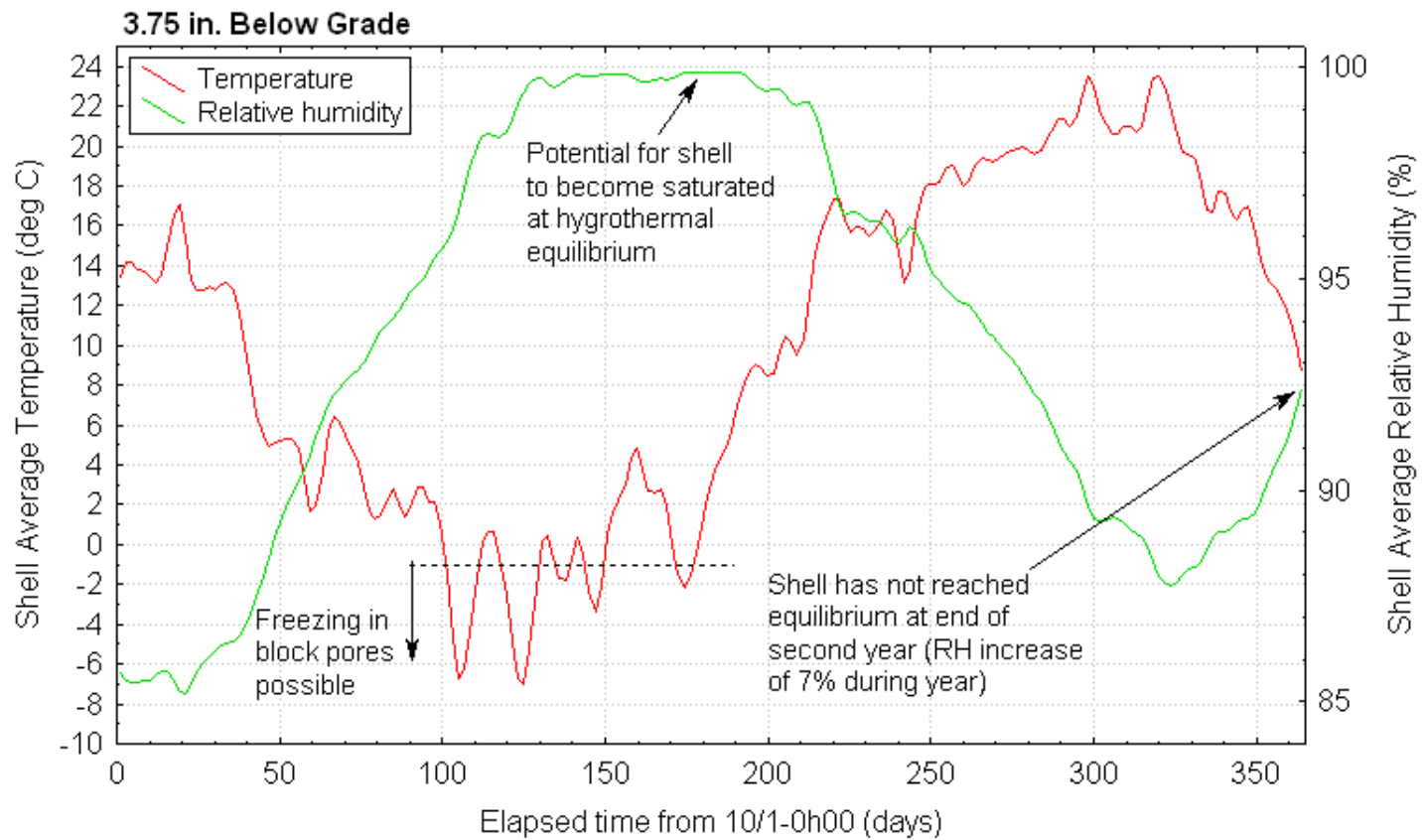

Figure B.30

B.9 **Masonry Block Wall with an Exterior Adhered WSP, R-10 Exterior and R-5 Interior Extruded Polystyrene Insulation**

Split rigid insulation systems are evaluated in Sections B.9 and B.10. In these systems, the required R-15 rigid insulation is split between the interior and exterior surfaces. It is very important to note that this review has included a hygrothermal evaluation only, not the energy performance impacts⁶.

An R-10 exterior / R-5 interior system is depicted in Figure B.31. An exterior WSP system was used based on the results of sections B.4 and B.5. Of note in Figure B.31 was the addition of a 6-mil. polyethylene sheet between the insulation and the soil. This addition is a consequence of research conducted at Oak Ridge National Laboratory in which extruded polystyrene exposed to the soil for a long period (about 6 years) was found on excavation to have a moisture content of up to 200 % by mass and a reduction in thermal resistance to 56 % of the installed R-value⁷. The PI also personally has witnessed the demolition of an unprotected exterior extruded polystyrene insulation system on a commercial building in Minnesota. Walking on the excavated insulation caused significant amounts of water to ooze out.

The above grade portion of the insulation was protected from ultraviolet radiation damage by aluminum flashing that also served as the WSP, although any equivalent material would be satisfactory. There were no interior warm-side vapor retarders so that the vapor reaching the wall interior surface through the approximately 1.1 perm R-5 extruded polystyrene board would be stored in the CMU shell during the heating season and subsequently dried to the interior during the rest of the year as discussed in section B.5. Note that the 1.1 perm rating is for both wet and dry cup ASTM E96 tests, so the average heating season vapor transport through the insulation system is less than that through the 2-mil. PA-6 warm-side vapor retarder used in Section B.5.

The condensation plane results are shown in Figure B.32. As expected, the split insulation system had very good hygric performance with no evidence of condensation anywhere in the system even with the cores vapor-coupled to the soil through the footing. The highest RH was experienced 12 in. below grade on the WSP exterior surface (that is between the WSP and the exterior insulation). However, as this is outside the WSP, even if this became vapor saturated, it would not affect the compliance of this system with the performance criteria.

⁶ From a purely energy perspective, there is no justification for splitting the insulation between the interior and exterior wall surfaces. The thermal effectiveness (3-dimensional heat flux/1-dimensional heat flux at a given total wall R-value) is significantly worse for split insulation systems on basement walls compared with unitary or single-location insulation systems.

⁷ Personal communication with M. Kehrer, Senior R&D Staff, Oak Ridge National Laboratory.

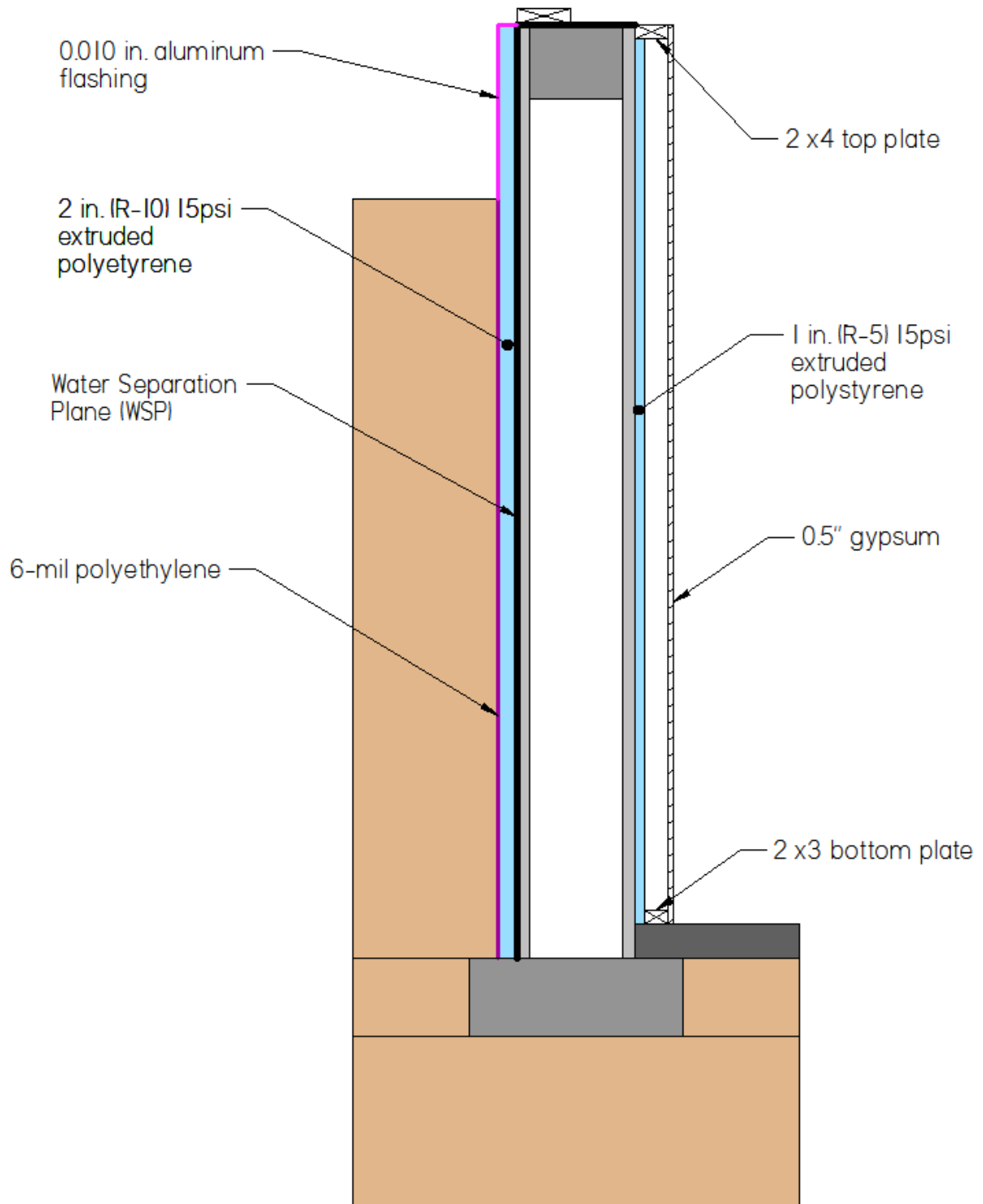

Figure B.31 Base + wall top and exterior full height wall adhered WSP + exterior R-10 and interior R-5 extruded polystyrene insulation

**MASONRY BLOCK WALL WITH EXTERIOR WSP, R10 EXTERIOR & R5 INTERIOR XPS INSULATION:
RELATIVE HUMIDITY TIME SERIES**

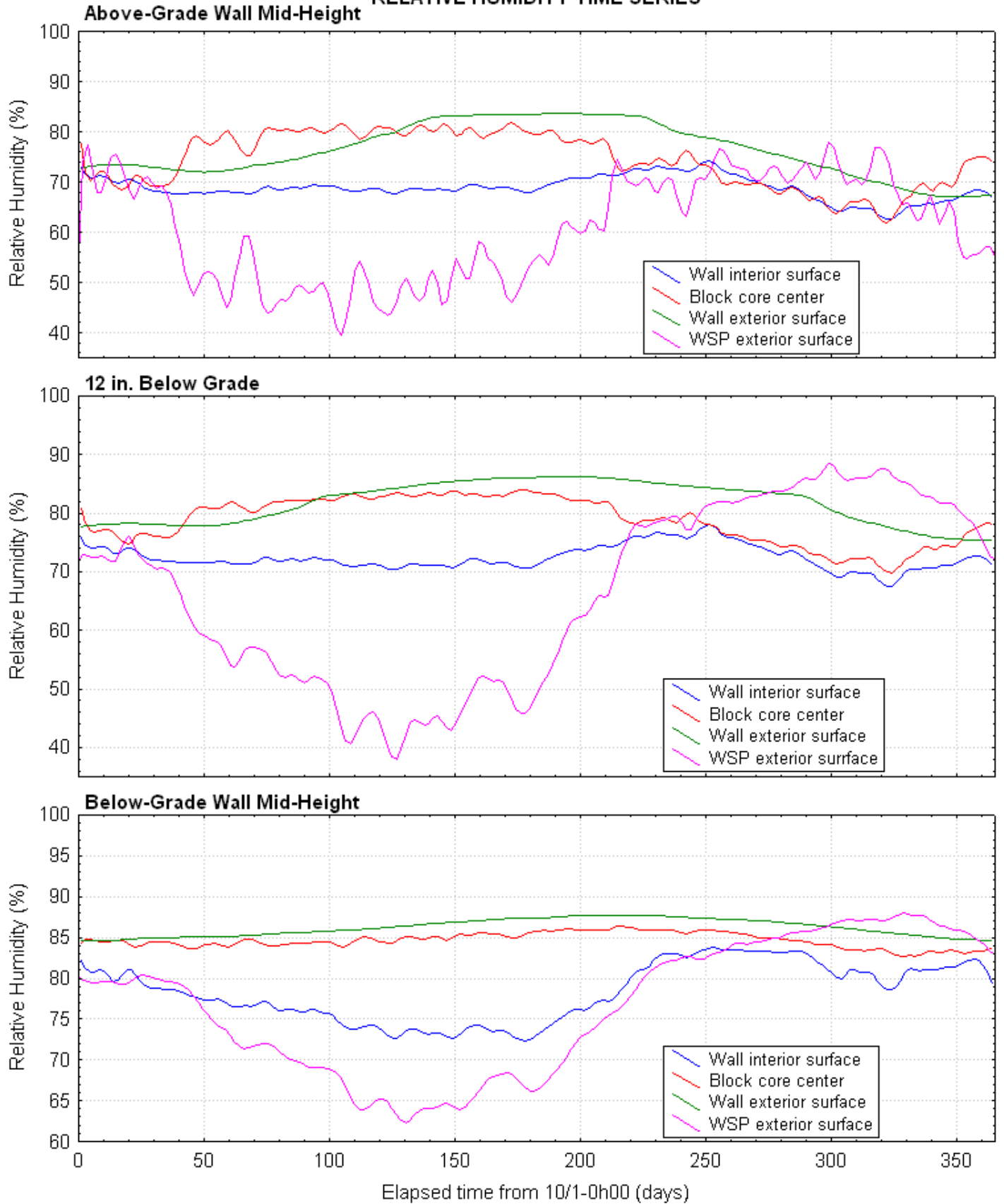

Figure B.32

B.10 Masonry Block Wall with an Exterior Adhered WSP, R-5 Exterior and R-10 Interior Extruded Polystyrene Insulation

In this system, the R-5 insulation was on the exterior with R-10 on the interior as shown in Figure B.33. All other aspects of the system are the same as Figure B.31.

As before, Figure B.34 reveals no condensation anywhere in the wall system. Of interest is that 12 in. below grade, the maximum interior wall surface RH was 86 %. This may be compared with 77 % experienced at the same location in Figure B.32 since R-5 extruded polystyrene allows greater drying to the interior even though a larger amount of vapor is transported through it from the interior as well. The reason, as before, is that the vapor transport through the footing can more readily dry to the interior with R-5 extruded polystyrene insulation than with R-10 (permeance of 0.55 perm). With the addition of a footing WSP to decouple the block cores from the soil, this advantage of R-5 insulation on the interior would disappear.

Thus the data of Sections B.9 and B.10 reveal that the split insulation system was in compliance with the performance criteria.

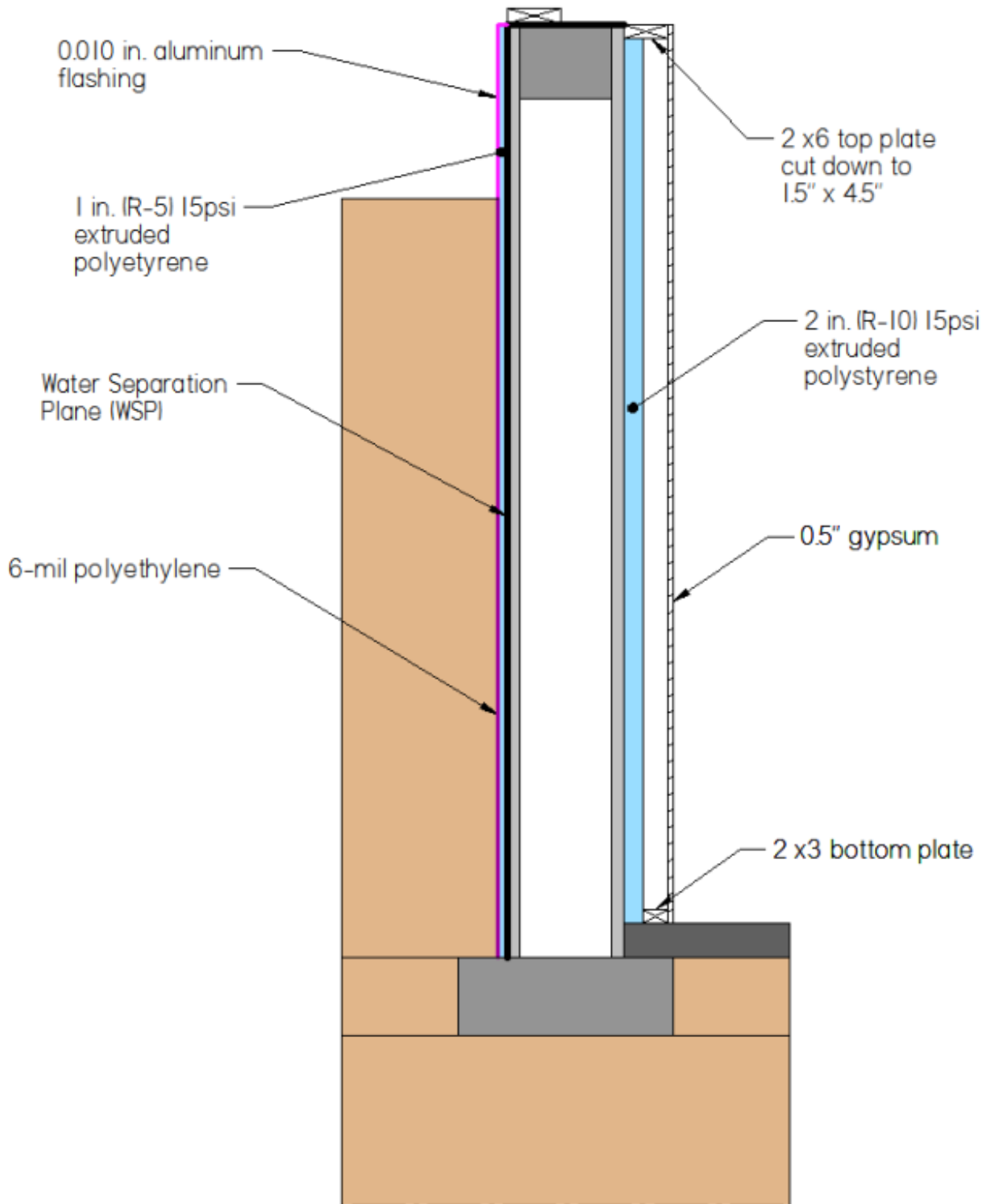

Figure B.33 Base + wall top and exterior full height wall adhered WSP + exterior R-5 and interior R-10 extruded polystyrene insulation

**MASONRY BLOCK WALL WITH EXTERIOR WSP, R5 EXTERIOR & R10 INTERIOR XPS INSULATION:
RELATIVE HUMIDITY TIME SERIES**

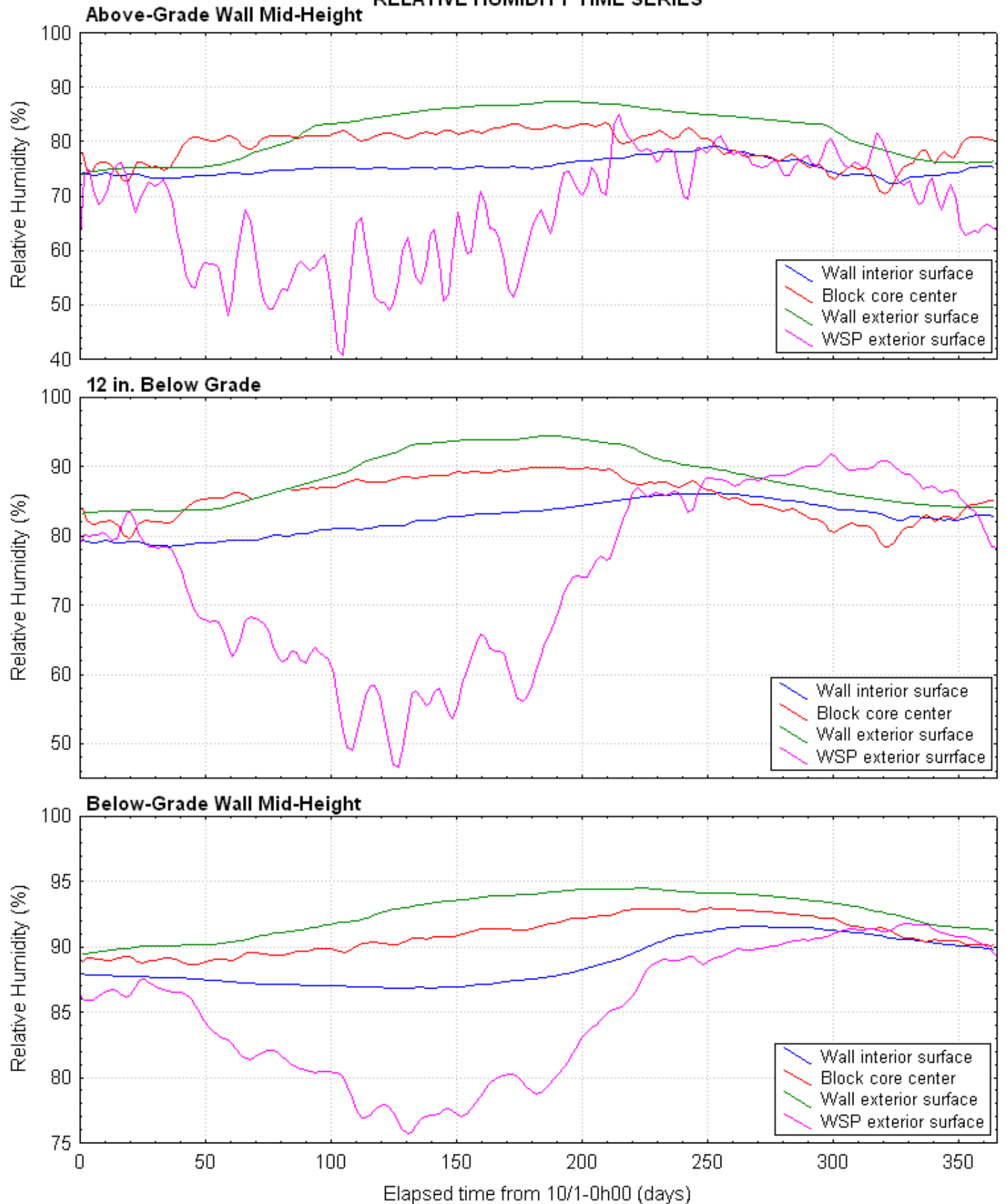

Figure B.34

C. RECOMMENDATION: REVISED PERFORMANCE REQUIREMENTS

Definition

WATER SEPARATION PLANE. A single component or a system of components creating a plane that effectively resists capillary water flow and water flow caused by hydrostatic pressure and provides a water vapor permeance of 0.1 perms or less to retard water vapor flow by diffusion.

R402.1.1.8 Foundation wall insulation performance option. Insulated foundation systems designed and installed under the performance option shall meet the requirements of this section.

Water separation plane. The foundation shall be designed and built to have a continuous water separation plane between the interior and exterior. The interior side of the water separation plane must:

1. have a stable annual wetting/drying cycle whereby foundation wall system water (solid, liquid, and vapor) transport processes produce no net accumulation of ice or water over a full calendar year and the foundation wall system is free of absorbed water for at least four months over a full calendar year;
2. prevent conditions of moisture and temperature to prevail for a time period favorable to mold growth for the materials used; and
3. prevent liquid water from the foundation wall system from reaching the foundation floor system at any time during a full calendar year.

Documentation. The foundation insulation system designer shall provide documentation certified by a professional engineer licensed in Minnesota demonstrating how the requirements of this section are fulfilled. The foundation insulation system designer shall also specify the design conditions for the wall and the design conditions for the interior space for which the water separation plane will meet the requirements of this section. The foundation insulation system designer shall provide a label disclosing these design conditions. The label shall be posted in accordance with Section N1101.8.

Installation. The water separation plane shall be designed and installed to prevent external liquid or capillary water flow across it after the foundation is backfilled.

Foundation air barrier. The foundation insulation system shall be designed and installed to have a foundation air barrier system between the interior and the exterior. The foundation air barrier system must be a material or combination of materials that is continuous with all joints sealed and is durable for the intended application. Material used for the foundation air barrier system must have an air permeability not to exceed 0.004 ft³ /min.ft² under a pressure differential of 0.3 inches water (1.57 psf) (0.02 L/s.m² at 75Pa) as determined by either commonly accepted engineering tables or by being labeled by the manufacturer as having these values when tested in accordance with ASTM E2178.

Structural. The water saturation ratio in the wall structural components shall not exceed the critical water saturation ratio at the freezing temperature for the prevailing vapor pressure in the pores of the structural materials at any time during a calendar year.

D. RECOMMENDATION: REVISED PRESCRIPTIVE RULES

R402.1.1.1 Water Separation Plane: Poured concrete and masonry block foundation walls shall have a continuous water separation plane between the interior and the exterior with the following requirements:

1. shall extend from the top interior wall edge, across the top of the wall and down the exterior wall face to the top of the footing;
2. shall connect the exterior wall face at the top of the footing to the sub-slab vapor retarder so that the wall bottom surface is water vapor and bulk-water isolated from the soil;
3. shall be sealed to the sub-slab vapor retarder, and;
4. if exposed to the ambient surroundings, the water separation plane shall have a rigid, opaque, and weather-resistant protective covering to prevent the degradation of the water proofing performance. The protective covering shall cover the exposed water separation plane and extend a minimum of six inches (152 mm) below grade. The protective covering system shall be flashed in accordance with IRC Section R703.8.

R402.1.1.4-2 Integral foundation insulation requirements. Any insulation assembly installed integral to the foundation walls shall be manufactured for its intended use and installed according to the manufacturer's specifications.

R402.1.1.4-3 Exterior draining foundation insulation requirements. Any insulation assembly installed on the exterior of the foundation walls and the perimeter of slabs-on-grade that allows drainage of bulk water:

1. shall be of water-resistant materials manufactured for its intended use;
2. shall be installed according to the manufacturer's specifications;
3. shall comply with ~~either~~ ASTM C578, C612, ~~or C1029 as applicable;~~ and
4. shall have a rigid, opaque, and weather-resistant protective covering to prevent the degradation of the insulation's thermal performance. The protective covering shall cover the exposed exterior insulation and extend a minimum of six inches (152 mm) below grade. The insulation and protective covering system shall be flashed in accordance with IRC Section R703.8.

R402.1.1.4 Exterior non-draining foundation insulation requirements. Any insulation assembly installed on the exterior of the foundation walls and the perimeter of slabs-on-grade that does not allow the drainage of bulk water:

1. shall be of water-resistant materials manufactured for its intended use;
2. shall be installed according to the manufacturer's specifications;
3. shall comply with either ASTM C578 or C1029 as applicable;
4. shall be covered with a 6-mil polyethylene slip sheet over its entire exterior surface; and
5. shall have a rigid, opaque, and weather-resistant protective covering to prevent the degradation of the insulation's thermal performance. The protective covering shall cover the exposed exterior insulation and extend a minimum of six inches (152 mm) below grade. The insulation and protective covering system shall be flashed in accordance with IRC Section R703.8.

R402.1.1.3-5 Interior foundation insulation requirements. Any insulation assembly installed on the interior of foundation walls shall meet the following provisions:

~~1. Masonry foundation walls shall be drained through each masonry block core, to an approved interior drainage system.~~

~~2.1. If a frame wall is installed, it shall not be in direct contact with the foundation wall unless that interior side of the foundation wall has been waterproofed.~~

~~3.2. Comply with the interior air barrier requirements Of Section R402.4.~~

~~4.3. Comply with Section R402.1.1.46, R402.1.1.57, R402.1.1.68, or R402.1.1.79, as applicable.~~

R402.1.1.4-6 Rigid interior insulation. Rigid interior insulation shall comply with the following:

1. Either ASTM C578 or ASTM C1289.

~~2. Dampproofing, waterproofing, or a water repellent shall be applied to the exposed above grade foundation walls or a layer of dampproofing or waterproofing shall be installed on the entire inside surface of the foundation wall. Dampproofing and waterproofing shall be in compliance with the provisions of dampproofing or waterproofing located in the International Residential Code (IRC). Water repellent materials shall comply with ASTM E514 with 90 percent or greater reduction in water permeance when compared to an untreated sample.~~

~~3.2. Installation requirements:~~

~~a. must be in contact with the foundation wall surface;~~

~~b. vertical edges shall be sealed with acoustic sealant;~~

~~c. all interior joints, edges, and penetrations shall be sealed against air and water vapor penetration;~~

~~d. horizontally continuous acoustic sealant exists-is applied between the foundation wall and the insulation at the top of the foundation wall; and~~

~~e. horizontally continuous acoustic sealant exists-is applied between the basement floor and the bottom insulation edge.~~

4. The insulation shall not be penetrated by the placement of utilities or by fasteners or connectors used to install a frame wall.

R402.1.1.5-7 Spray-applied interior foam insulation. Spray-applied interior foam insulation shall comply with the following as applicable for:

1. Closed cell foam.

a. ASTM C1029 compliant with a permeance not greater than ~~4-0~~ 0.8 in accordance with ASTM E96 procedure A and a permeance not less than 0.3 in accordance with ASTM E96 procedure B.

b. Sprayed directly onto the foundation wall surface. There must be a one-inch minimum gap between the foundation wall surface and any framing.

c. The insulation shall not be penetrated by the placement of utilities.

d. Through penetrations shall be sealed.

2. Open cell foam.

a. Sprayed directly onto the foundation wall surface. There must be a one-inch minimum gap between the foundation wall surface and any framing.

b. The insulation shall not be penetrated by the placement of utilities.

c. Through penetrations shall be sealed.

d. A vapor retarder and air barrier shall be applied to the warm in winter side of the assembly with a permeance not greater than 1 in accordance with ASTM E96 procedure A and a permeance not less than 0.3 in accordance with ASTM E96 procedure B.

R402.1.1.6 Semi-rigid interior insulation. Semi-rigid interior insulation shall comply with the following:

1. ~~The above-grade exposed wall height shall not exceed 3 ft.~~
2. ~~ASTM C1621 with a maximum permeance of 1.1 per inch.~~
3. ~~Must have a minimum density of 1.3 pcf and have a fungal resistance per ASTM C1338.~~
4. ~~Installation requirements:~~
 - a. ~~Must be in contact with the foundation wall surface;~~
 - b. ~~Vertical edges shall be sealed with acoustic sealant;~~
 - c. ~~All interior joints, edges, and penetrations shall be sealed against air and water vapor penetration;~~
 - d. ~~Horizontally continuous acoustic sealant shall be applied between the foundation wall and the insulation at the top of the foundation wall; and~~
 - e. ~~Horizontally continuous acoustic sealant shall be applied between the basement floor and the bottom insulation edge.~~

R402.1.1.7-8 Fiberglass batt interior insulation. Fiberglass batt interior insulation shall comply with the following:

1. ~~Waterproofing shall be applied to the entire inside surface of the foundation wall. The above-grade exposed wall height shall not exceed 3 ft.~~
2. The top and bottom plates must be air sealed to the foundation wall surface and the basement floor.
3. ~~A vapor retarder and air barrier shall be applied to the warm in winter side of the assembly with a permeance not greater than 1 in accordance with ASTM E96 procedure A and a permeance not less than 0.3 in accordance with ASTM E96 procedure B an air barrier material and vapor retarder material with a minimum permeance of at least 1, in accordance with ASTM E96 procedure A, shall be installed on the warm in winter side of the foundation insulation~~ meeting the following:
 - a. Air sealed to the framing with construction adhesive or equivalent at the top and bottom plates and where the adjacent wall is insulated;
 - b. Air sealed utility boxes and other penetrations; and
 - c. All seams shall be overlapped at least six inches and sealed with compatible sealing tape or equivalent.

R402.1.1.9 Interior and exterior rigid insulation The exterior component shall be in compliance with R402.1.1.4. The interior component shall be in compliance with R402.1.1.6.

E. REFERENCES

- Goldberg, L.F. and T.Aloi, 2001. Space Humidity/Interior Basement Wall Insulation Moisture Content Relationships With and Without Vapor Retarders, *ASHRAE IAQ 2001 Conference Proceedings*, San Francisco.
- Goldberg, L.F., 2002. Owens Corning Basement Insulation System Experimental Evaluation Project, <http://www.buildingfoundation.umn.edu/OCBasementSystem/default.htm>, University of Minnesota.
- Goldberg, L.F. and P.H. Huelman, 2005. Minnesota Energy Code Building Foundation Rule: Amendment Proposal Development Project Final Report, Project Research Report, <http://www.buildingfoundation.umn.edu/FinalReportWWW/default.htm>, ESDP, University of Minnesota.
- Goldberg, L.F., 2006. Polyamide-6 Based Interior Foundation Insulation System: Experimental Evaluation, ESDP Research Report, <http://www.buildingfoundation.umn.edu/CT-FTF/default.htm>, University of Minnesota.
- Goldberg, L.F., P.H. Huelman and S.D. Gatland II, 2010. A Prototype Universal Building Envelope Hygrothermal Performance Standard for Successful Net-Zero Energy Building Design, *Proc. Buildings XI, ASHRAE*, Clearwater Beach.
- Goldberg L.F. and M.L. Stender, 2011a. Exterior Wall Assembly Including Moisture Transportation Feature, United States Patent no. US 8001736 B2.
- Goldberg L.F. and M.L. Stender, 2011b. Exterior Wall Assembly Including Moisture Removal Feature, United States Patent no. US 8074409 B2.
- Hoang, C.P., K.A. Kinney, R.L. Corsi and P.J. Szanislo, 2010. Resistance of green building materials to fungal growth, *International Biodeterioration & Biodegradation*, vol. 64, no. 2, pp. 104-113.
- Kunzel, H.M., 1995. Simultaneous Heat and Moisture Transport in Building Components, IRB Verlag.
- Litvan, G.G., 1980. Freeze-Thaw Durability of Porous Building Materials, in *Durability of Building Materials and Components*, ASTM Special Technical Publication no. 691, pp. 455-463.
- National Concrete Masonry Association, 2011. NCMA Performance Guidelines for Concrete Masonry Units, revised 5/2/2011.
- Olsen, M.P.J., 1984. Mathematical Modeling of the Freezing Process of Concrete and Aggregates, *Cement and Concrete Research*, vol. 14, pp. 113-122.
- Sedlbauer, K., 2001. Prediction of mould fungus formation on the surface of and inside building components, Dissertation Universität Stuttgart, http://www.hoki.ibp.fhg.de/ibp/publikationen/dissertationen/ks_dissertation_e.pdf.

Sedlbauer, K., M. Krus and K. Breuer, 2003. Mould Growth Prediction with a New Biohygrothermal Method and its Application in Practice, Proc. Materials Conference, Lodz, pp 594-601, http://www.hoki.ibp.fhg.de/ibp/publikationen/konferenzbeitraege/pub1_43.pdf

Wang, C.Y. and P. Cheng, 1997. Multiphase Flow and Heat Transfer in Porous Media, *Advances in Heat Transfer*, vol. 30, pp. 93-196.